

ELECTROCRRAFT
CompletePower™ Plus
EZ DRIVE

CPP-A24V48A-SA-EZ
CPP-A12V48A-SA-EZ
CPP-A06V48A-SA-EZ
Drive User Manual



ElectroCraft CompletePower™ Plus EZ Drive

ElectroCraft document number: 198-0000100



Record of Revisions:

Revision	Date	Description	Comments
001		Initial Release	Document created.
002		Update for peak current	Removed peak current specification.

Read This First

While ElectroCraft believes that the information and guidance given in this manual is correct, all parties must rely upon their own skill and judgment when making use of it. ElectroCraft does not assume any liability to anyone for any loss or damage caused by any error or omission in the work, whether such error or omission is the result of negligence or any other cause. Any and all such liability is disclaimed.

All rights reserved. No part or parts of this document may be reproduced or transmitted in any form or by any means, electrical or mechanical including photocopying, recording or by any information-retrieval system without permission in writing from ElectroCraft, Inc. The information in this document is subject to change without notice.

About This Manual

This document is a Drive User Manual for CPP-A24V48A-SA-EZ, CPP-A12V48A-SA-EZ and CPP-A06V48A-SA-EZ. This document covers the drive hardware including technical data, connectors and wiring diagrams needed for installation.

ElectroCraft
2 Marin Way, Suite 3
Stratham, NH 03885-2578

If you need Assistance ...

Visit ElectroCraft online

World Wide Web: www.electrocraft.com

If you would like to ...

- Receive general information or assistance
- Ask questions about product operation or report suspected problems
- Make suggestions or report errors in documentation

Contact ElectroCraft ...

For regional technical, application and sales support for ElectroCraft and Hansen Products:

North America / USA / Mexico / South America / Central America

Contact: +1 (844) 338-8114, sales@electrocraft.com

Europe (except Germany), Middle East, Africa, Australia

Contact EMEA Sales Team, +44 (0) 1270 508 800, EMEAsales@electrocraft.com

Germany

Contact customer service, +49 (0) 711 727 2050, info@de.electrocraft.com

Asia

Contact customer service, sales@electrocraft.com

Contents

1	Product Safety Precautions	6
1.1	Operation	6
1.2	Storage and Transportation	7
1.3	Environmental Protection	7
1.4	Installation	8
1.5	Wiring	8
1.6	Life Support Policy	9
1.7	Checking Product on Delivery	9
2	Product Overview	11
2.1	Key Features	11
2.2	Simplified System Block Diagram	11
2.3	Hall Sensor Feedback for BLDC motor	12
2.4	Digital Tach/Encoder Feedback	13
2.5	Identification Labels	13
2.6	Status Indicator Lights	13
3	Drive Specifications	14
3.1	Physical Specifications	14
3.2	Environmental Specifications	14
3.3	Electrical Specifications	14
3.3.1	DC Supply Input	14
3.3.2	+5VDC Supply Output	14
3.3.3	Motor Output	14
3.3.4	Hall Sensor Inputs	15
3.3.5	Digital Tach/Encoder Input	15
3.3.6	Digital Input	15
3.3.7	Digital Output	15
3.3.8	Analog Input (Speed Control)	16
3.4	De-rating	16
4	Hardware Installation	17
4.1	Mechanical Mounting	17
4.2	Dimensions	17
4.3	Mating Connectors	17
4.4	Connector Locations and Pin Numbers	18
4.4.1	Connector Layout	18
4.4.2	J1 Supply and Motor Connector Pinout	18
4.4.3	J2 I/O Connector Pinout	19
4.4.4	J3 Hall and Tach or Encoder Connector Pinout	19
5	Connecting Power & Motors	20
5.1	Power supply & BLDC Connections	20

6	Connecting Motor Feedback Devices.....	20
6.1	Feedback Connections.....	20
6.1.1	Hall & Tach/Encoder Sensor Connections.....	20
6.1.2	Hall Sensor Signal Input Circuit.....	21
6.1.3	Digital Tach/Encoder Input Circuit.....	21
7	Connecting I/O.....	22
7.1	I/O Functional Description.....	22
7.2	I/O Connections.....	23
7.2.1	I/O Connections for Internal Speed Control Operation.....	23
7.2.2	Standard I/O Connections.....	24
7.3	Digital Inputs and Outputs.....	24
7.3.1	Digital Input Circuit.....	24
7.3.2	Digital Output Circuit.....	25
7.4	Analog Inputs and Outputs.....	25
7.4.1	Analog Input Circuit.....	25
7.5	Tach Output Speed Calculation.....	25
7.5.1	Hall Mode Speed Calculation.....	25
7.5.2	Tach Mode Speed Calculation.....	25
8	User Settings.....	26
8.1.1	User Max Speed Setting.....	27
8.1.2	User Max Current Setting.....	27
9	First Time Operation.....	28
10	Troubleshooting.....	29
10.1	Status LED (Red) Fault Codes.....	29
10.2	Power LED (Green).....	30

Table of Figures

FIGURE 1: DRIVE SYSTEM BLOCK DIAGRAM.....	11
FIGURE 2: TRAPEZOIDAL COMMUTATION WITH HALL SENSOR FEEDBACK	12
FIGURE 3: DIGITAL TACH FEEDBACK SIGNAL	13
FIGURE 4: DRIVE WITH IDENTIFYING LABEL	13
FIGURE 5: DRIVE DIMENSIONS.....	17
FIGURE 6: DRIVE CONNECTOR LAYOUTS	18
FIGURE 7: POWER SUPPLY & MOTOR CONNECTIONS TO EZ DRIVE	20
FIGURE 8: FEEDBACK SENSOR CONNECTIONS TO EZ DRIVE	20
FIGURE 9: HALL SENSOR INPUT CIRCUIT	21
FIGURE 10: TACH/ENCODER INPUT CIRCUIT	21
FIGURE 11: MINIMUM I/O CONNECTIONS FOR INTERNAL SPEED CONTROL OPERATION	23
FIGURE 12: POTENTIOMETER LOCATION	23
FIGURE 13: STANDARD I/O CONNECTIONS	24
FIGURE 14: DIGITAL INPUT CIRCUIT	24
FIGURE 15: DIGITAL OUTPUT CIRCUIT	25
FIGURE 16: ANALOG INPUT CIRCUIT (SPEED CONTROL).....	25
FIGURE 17: JUMPERS FOR USER SETTINGS.....	26

1 Product Safety Precautions

READ THIS ENTIRE SECTION BEFORE ATTEMPTING TO USE THE CPP-AXXV48A-SA-EZ DRIVE!
GIVE SPECIAL ATTENTION TO ALL BOLD PRINT ITEMS.



WARNING!

ElectroCraft products are not authorized for use in safety critical applications. To operate the drive safely, these minimum precautions **MUST** be followed to insure proper performance without injury to the operator and damage to motor or drive. **FAILURE TO OBSERVE THESE SAFETY PRECAUTIONS COULD RESULT IN SERIOUS BODILY INJURY, INCLUDING DEATH IN EXTREME CASES.**

1.1 Operation

1. Do not touch any of the connector pins on connectors J1 (Supply Input and Motor Output) when power has been applied. Bare wires from adjacent connector pins must never be allowed to touch one another.
2. J1 pin 3 must be connected to an external earth ground. Follow wiring procedures carefully.
3. Read ElectroCraft Life Support Policy in section 1.6 for application limitations.
4. Follow precautionary guidelines as referenced in section 0 of this manual about proper installation of an optional external brake resistor.
5. Do not operate the drive in an explosive area or near explosive or flammable materials.
6. Do not use the drive in environments where it is likely to be exposed to strong and/or frequent static discharge.
7. Conduct trial operations on the servo drive alone with the motor shaft disconnected from the load to avoid any unexpected motion. Motor shaft should be uncoupled and free to rotate without coming in contact with user or any stationary object during set up and preliminary operation.
8. Under no circumstances should a phase output from the control be connected to anything other than a passive inductive/resistive motor load. Short circuit protection for the drive is limited to momentary conditions only! Repetitive short circuits on any of the output pins of J2 may cause permanent damage to the drive.
9. Never touch any moving parts while the motor is running. Failure to observe this warning may result in injury.
10. Excessive speed and current can destroy some motors and possibly injure the user. Check the motor manufacturer's specifications to ensure that the maximum current and voltage for your drive model, does not exceed motor limitations.
11. Whenever the drive is disabled for any reason or unpowered, the motor will be in free spinning/coast mode. The user is responsible to analyze the application (especially in case of servomotor for a vertical axis) and take precautionary safety measures.
12. Provide an appropriate stopping device on the machine side to ensure safety. Failure to observe this warning may result in injury.
13. Do not parallel multiple motors off the same drive.
14. Do not make any extreme adjustments or settings changes of parameters. Failure to observe this caution may result in injury due to unstable operation.

-
15. Avoid plugging connector J1 into the drive while live power is applied to the connecting cables. Ignoring this precaution will cause electrical arcing at the connector pins, which can cause permanent connector damage. ElectroCraft recommends using a disconnect switch ahead of J1 if the drive must be disconnected often.
 16. Do not remove the connectors on ports J1 through J6 from the drive while the motor is operating.
 17. Do not service or modify this product. Only authorized personnel must perform disassembly or repair of the drive. Failure to observe warning may result in injury or damage to product.
 18. Always operate the drive within the prescribed voltage limits. Any attempt to operate outside these bounds may result in damage to the drive.
 19. Safe use of this product depends on factors specific to the end application. These factors are outside of ElectroCraft knowledge and control. The installer of this servo drive must have a thorough knowledge of safety precautions and practices relevant to the specific application of this drive. In particular the installer should consider the risks associated with erroneous or non-operation of the servo drive in the application and mitigate them appropriately.

1.2 Storage and Transportation

1. Do not store or install the product in the following places:
 - a. Locations subject to temperature outside of the range specified.
 - b. Locations subject to humidity outside the range specified.
 - c. Locations subject to condensation as the result of changes in temperature.
 - d. Locations subject to corrosive or flammable gases and liquids.
 - e. Locations subject to dust, salts, or electrically conductive contaminants.
 - f. Locations subject to exposure to water, oil, or chemicals.
 - g. Locations subject to shock or vibration.

Failure to observe this caution may result in fire, electric shock, or damage to the product.

2. Do not hold the product by the cables or motor shaft while transporting it. Failure to observe this caution may result in injury or malfunction.

1.3 Environmental Protection

Waste electrical products should not be disposed of with household waste. Please recycle where facilities exist. Check with your Local Authority or retailer for recycling.



1.4 Installation

1. Take appropriate and sufficient countermeasures when installing systems in the following locations.
 - a. Locations subject to static electricity or other forms of noise.
 - b. Locations subject to strong electromagnetic fields and magnetic fields.
 - c. Locations subject to possible exposure to radioactivity.
 - d. Locations close to power supplies including power lines.Failure to observe this caution may result in damage to the product.
2. Keep any external shunt/brake resistor away from flammable materials. Read section 13 carefully for more shunt/brake resistor installation details.
3. Never use this product in an environment subject to liquids, corrosive chemicals or gases; or combustibles; or where foreign materials can fall onto or collect inside the drive. Failure to observe this caution may result in electric shock or fire.
4. Do not place any objects on the product. Failure to observe this warning may result in damage to the product.
5. Do not cover the drive or prevent air from escaping or entering through the vents. Failure to observe this caution may cause internal elements to deteriorate resulting in malfunction or fire.
6. Provide the specified clearance between the drive and other devices. Provide sufficient space around the drive for cooling by natural convection or provide cooling fans to prevent excessive heat. See section 5 for details. Failure to observe this caution may result in fire or malfunction.

1.5 Wiring

1. Verify **ALL** wiring **BEFORE** applying power to the drive and motor. Motor may spin or oscillate uncontrollably if improperly wired. Drive may be damaged or improper wiring may prevent drive from operation.
2. J1 pin 3, PE, **MUST** always be connected to an appropriate external Protective Earth ground in accordance with local electrical codes. Improper grounding may result in electric shock and damage the drive.
3. Securely connect the power supply terminals and motor output terminals. Failure to observe this caution may result in fire.
4. Do not bundle or run power and signal lines together in the same duct. Keep power and signal lines separated.
5. Always use the specified power supply voltage. An incorrect power supply may result in damage to the drive.

Installation requirements for EMC CE compliance:

For EMC compliance, correct cable selection and wiring practices are mandatory. The following contains installation instructions necessary for meeting EMC requirements.

- Shielded cables are mandatory for the motor, power and control cabling to the drive. The power and motor cables must be bonded to earth at both ends and the control bonded to earth at one end. The shield of the cable must be grounded at the closed ground point with the least amount of resistance and inductance.
- Motor cables should not exceed 10m (32.8ft) in length. For best results use ElectroCraft series cables.
- Segregate the drive power wiring and motor phase cables from the control wiring and feedback cabling. When using shielded cables for the power wiring, provide a grounded 360 degree clamp termination at both ends. Provide for a large contact area between shields and the mounting plate.

1.6 Life Support Policy

READ THIS ENTIRE SECTION BEFORE ATTEMPTING TO USE THE CPP-AXXV48A-SA-EZ DRIVE!

ElectroCraft products are not authorized for use as critical components in life support devices or systems without the express written approval from ElectroCraft, Incorporated.

1. Life support devices or systems are intended for surgical implant into the body, or support or sustain life, and whose failure to perform, when properly used in accordance with instructions for use provided in the Drive User Manual and in the labeling, can be reasonably expected to result in a significant injury to the user.
2. A critical component is any component of a life support device or system whose failure to perform can be reasonably expected to cause the failure of the life support device or system, or to affect its safety or effectiveness.

1.7 Checking Product on Delivery

When your package arrives, inspect the shipping box and the unit carefully, and save ALL packing materials. Compare the packing slip against all items included in the shipping box. Any shortages or other inspection problems should be reported to ElectroCraft immediately.

The following procedure is used to check products upon delivery. Check the following items when your CPP-AXXV48A-SA-EZ is delivered.

- Verify that the model number marked on the nameplate of the drive(s) is the correct model ordered.
- Check the overall appearance. Check for damage or scratches that may have occurred during shipping.

If any damage is noted, or if the unit is the wrong type, contact your ElectroCraft sales representative immediately.

Your CPP-AXXV48A-SA-EZ has arrived carefully packaged from ElectroCraft, in an antistatic bag. As you unseal this bag, inspect the contents carefully. There should not be any loose or damaged parts inside.

Never attempt to operate or power-up the drive if there is any visible external damage or if there are loose materials inside the chassis. While unpacking, if you discover any loose or damaged parts, notify ElectroCraft within two working days.

ElectroCraft recommends that all packing materials be saved in the event that the drive needs to be returned. Always place the drive in the same antistatic bag used in the original shipment. Anti-static filler material should always be placed around the drive so that it cannot shift inside the box. Extreme care should be exercised when placing packing material around all external connectors to prevent mechanical stress damage.

All material to be returned to ElectroCraft must have a Return Material Authorization (RMA) tracking number assigned before shipment. This can be obtained by contacting ElectroCraft. Any product returned without this number will be rejected by ElectroCraft.

Always insure your shipment for the proper replacement value of its contents. ElectroCraft will not assume responsibility for any returned goods that have been damaged outside of our factory because of improper packaging or handling. All goods shipped to ElectroCraft must be shipped FREIGHT PREPAID.

2 Product Overview

This manual describes the installation and operation of the CPP-AXXV48A-SA-EZ drive manufactured by ElectroCraft Inc.

2.1 Key Features

Features of EZ Drive

- +12 to +48 VDC power supply input
- 24 Amps max continuous for CPP-A24V48A-SA-EZ
- 12 Amps max continuous for CPP-A12V48A-SA-EZ
- 6 Amps max continuous for CPP-A06V48A-SA-EZ
- BLDC motor control
- 2 quadrant operation
- Trapezoidal commutation mode
- 25 kHz PWM frequency
- 0-10V analog command input for speed control
- Digital inputs for enable, direction & brake
- Digital outputs for tach and fault status
- Halls only operation mode
- Digital tach (or encoder) mode for low-speed performance
- 97% efficiency at full load

2.2 Simplified System Block Diagram

Overall system block diagram of EZ Drive is shown in Figure 1.

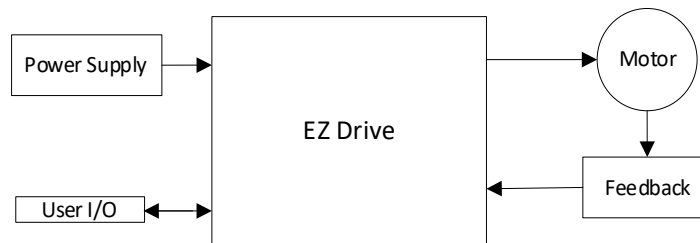

Figure 1: Drive System Block Diagram

2.3 Hall Sensor Feedback for BLDC motor

Drive can operate a BLDC motor using trapezoidal (6-step) commutation with hall sensor feedback as shown in Figure 2.

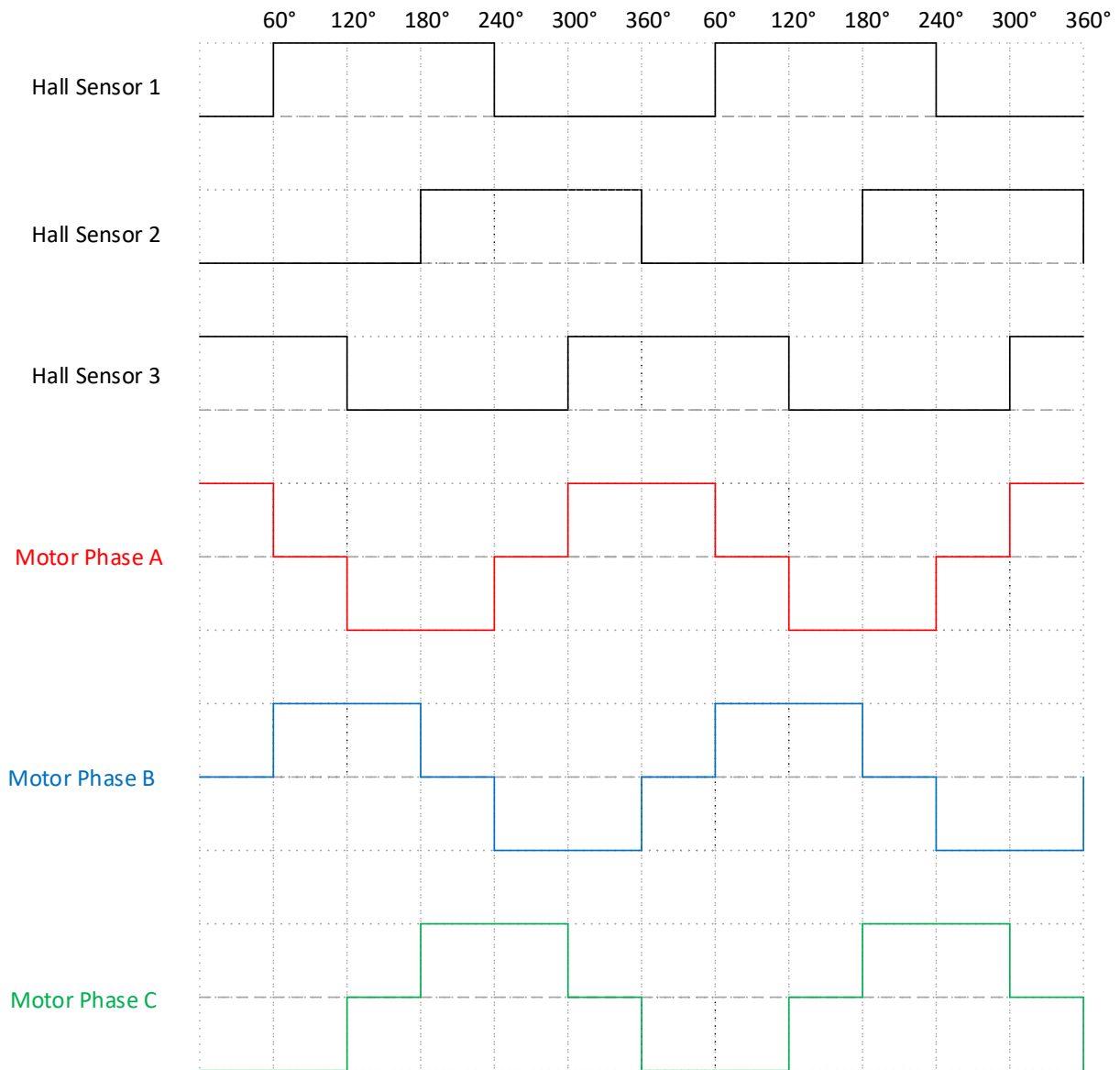

Figure 2: Trapezoidal Commutation with Hall Sensor Feedback

2.4 Digital Tach/Encoder Feedback

When tach mode is enabled, the drive reads the tach input (or single line encoder) for speed measurement. See example signal shown below in Figure 3 for a digital tach feedback signal.

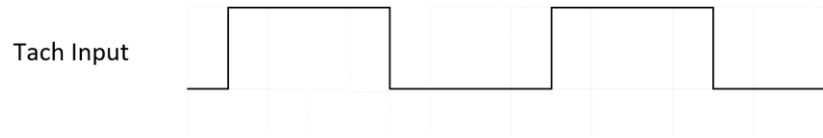

Figure 3: Digital Tach Feedback Signal

2.5 Identification Labels

See figure 4 which shows label location for product serial number.



Figure 4: Drive with identifying label

2.6 Status Indicator Lights

In normal operation, the drive is either in an “Enabled” state or in a “Disabled” state. When power is first applied, the green LED will be ON indicating that power has been applied. The Red LED should be Off, meaning no errors or faults. The Enable input can be used to switch between “Enabled” and “Disabled” states. Refer to section 10 for LED flash codes and possible causes.

3 Drive Specifications

Using the drive outside the specified absolute maximum ratings will damage the drive. Using the drive outside normal operating specifications may not guarantee a reliable operation.

3.1 Physical Specifications

Parameter	Conditions	Typical	Units
Weight	Without mating connectors	130	g
Dimensions (Without mating connectors)	Length x Width x Height CPP-A24V48A-SA-EZ	78.3 x 82.3 x 29.2	mm
		3.1 x 3.2 x 1.15	Inch
	Length x Width x Height for EZ Med/Low CPP-A12V48A-SA-EZ, CPP-A06V48A-SA-EZ	78.3 x 82.3 x 20.1	mm
		3.1 x 3.2 x 0.79	Inch

3.2 Environmental Specifications

Parameter	Conditions	Min.	Typical	Max.	Units
Ambient Temperature	Operating Range	0	-	40	°C
	Storage Range	-20	-	85	
Ambient Humidity	Non-condensing	5	-	95	%RH

3.3 Electrical Specifications

All ratings at ambient temperatures = 0 to 40°C and PWM frequency of 25 kHz (unless otherwise noted).

3.3.1 DC Supply Input

Parameter	Conditions	Min.	Typical	Max.	Units	
Supply Voltage	Operating Range	12	-	48	VDC	
	Absolute maximum	10.5	-	54		
Supply Current	Operating at max load	CPP-A24V48A-SA-EZ	-	-	24 ⁽¹⁾	A*
		CPP-A12V48A-SA-EZ	-	-	12 ⁽¹⁾	
		CPP-A06V48A-SA-EZ	-	-	6 ⁽¹⁾	
	Idle condition.	@ 12VDC	-	76	-	mA
@ 48VDC		-	21	-		

(1) Max Continuous rated current

* Values are peak of Sine

3.3.2 +5VDC Supply Output

Parameter	Conditions	Min.	Typical	Max.	Units
Output Voltage	Operating Range	4.9	5.0	5.1	VDC
Output Current	Combined current on all connectors	-	-	250	mA

3.3.3 Motor Output

Parameter	Conditions	Min.	Typical	Max.	Units	
Output Phase Current	Operating at max load	CPP-A24V48A-SA-EZ	-	-	24 ⁽¹⁾	A*
		CPP-A12V48A-SA-EZ	-	-	12 ⁽¹⁾	
		CPP-A06V48A-SA-EZ	-	-	6 ⁽¹⁾	

(1) Continuous rated current

* Values are peak of Sine

3.3.4 Hall Sensor Inputs

Parameter	Conditions	Min.	Typical	Max.	Units
Input Voltage	Operating Range	0	-	3.8	V
	Logic "low" operating	-	-	1	
	Logic "high" operating	2.3	-	-	
Sourcing Current	Logic "low" with internal 2.2K pull up to +3.3V	-	-	1.5	mA

3.3.5 Digital Tach/Encoder Input

Parameter	Conditions	Min.	Typical	Max.	Units
Input Voltage	Operating Range	0	-	5.0	V
	Logic "low" operating	-	-	0.25	
	Logic "high" operating	2.0	-	-	
Input Frequency		-	-	10	kHz
Minimum Pulse Width		50	-	-	μs

3.3.6 Digital Input

Parameter	Conditions	Min.	Typical	Max.	Units	
Input Voltage	Enable, Direction, Brake	Logic High	2.3	-	-	V
		Logic Low	-	-	1	
		Absolute maximum	-	-	24	
Sinking and Sourcing Current	Enable, Direction, Brake	Logic Low Sourcing	-	-	33	μA
		Logic High Sinking	-	-	4	mA
Input Frequency	Enable, Direction, Brake	Frequency	-	-	0.25	kHz
		Pulse Width	2	-	-	ms

3.3.7 Digital Output

Parameter	Conditions	Min.	Typical	Max.	Units	
Output Voltage	Tach Output, Fault Output	Operational range	0	-	5.1	V
		Absolute Max	-	-	24 ⁽¹⁾	
Sourcing Current ⁽²⁾	Tach Output, Fault Output	Absolute Max	-	-	2	mA
Sinking Current	Tach Output, Fault Output	Absolute Max	-	-	180	mA
External Load Impedance ⁽³⁾	Tach Output, Fault Output	Absolute Max	130	-	-	Ω

(1) **Note:** When voltage is applied externally.

(2) **Note:** When output is "OFF," and output pin is pulled to min operational voltage externally.

(3) **Note:** When output is "ON," and output pin is pulled up to max operational voltage externally.

3.3.8 Analog Input (Speed Control)

Parameter	Conditions	Min.	Typical	Max.	Units
Input Voltage	Operational range	0	-	10	V
	Absolute maximum	-	-	12	
Input Impedance		8	-	-	kΩ

3.4 De-rating

The drive is protected against overheating. The protection mechanism employed is to shut off current to the motor when the drive internal temperature reaches the maximum limit. The thermal performance of the drive is dependent on the application and the environmental conditions. This section provides guidance for application of the drive within the recommended operating conditions referenced in this manual.

The drive does not have any temperature or output PWM frequency derating in the ambient temperature range of 0 to 40°C when mounted according to ElectroCraft recommendations as specified in section 4.1. Operating the drive outside ElectroCraft recommendations or in a closed box and stagnant air may limit maximum performance. Use of additional heatsinking or forced air may be required. For applications outside ElectroCraft recommendations or in ambient temperature outside the limit of 0 to 40°C, please contact ElectroCraft.

4 Hardware Installation

4.1 Mechanical Mounting

Use the provided mounting holes and recommended mating connectors, as referenced in section 4.3. Provide at least 25 mm (1 in) of clearance between drives and at least 100 mm (4 in) of clearance above and below each drive when installing, for full rated operation of the drives or as needed for unimpeded natural convection. Install the drive using the slots provided which can accommodate up to M4 or #8 screw.

4.2 Dimensions

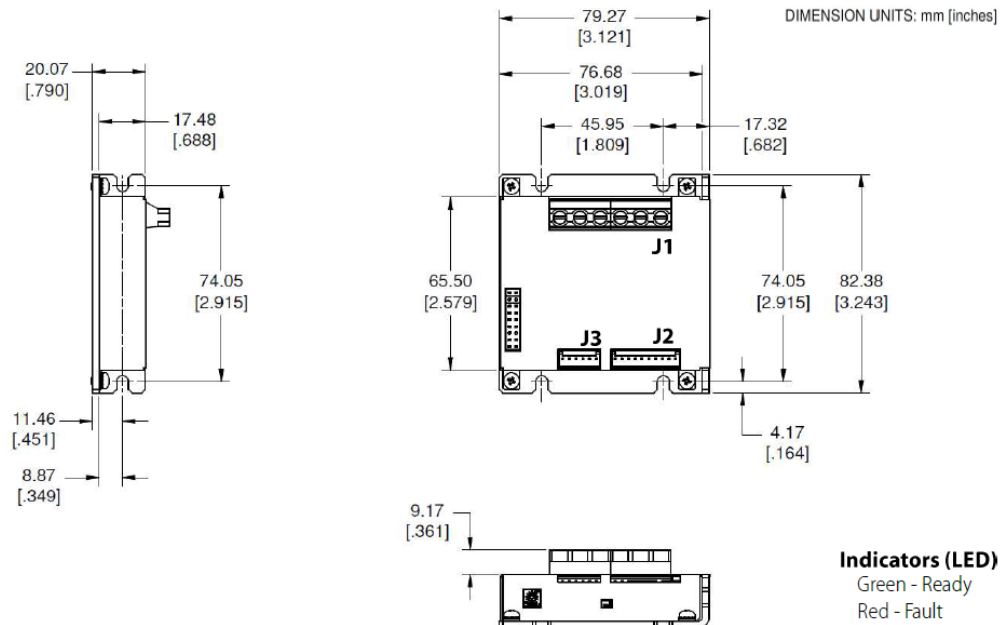

Figure 5: Drive Dimensions

4.3 Mating Connectors

Connector	Connector Name	Manufacturer	Mating Connectors P/N
J1	Supply & Motor	Terminal block: 10-22 AWG for CPP-A24V48A-SA-EZ Terminal block: 12-22 AWG for CPP-A12V48A-SA-EZ & CPP-A06V48A-SA-EZ	
J2	I/O	TE	4-643814-0
J3	Feedback (Hall, Tach)	TE	3-640441-6
-	Jumpers (2.54mm Shunt)	Adam Tech	MSBH-G
-	Crimp tool for J2, J3	TE	Crimper: 58074-1 Head: 58246-1 (MTA-100)

4.4 Connector Locations and Pin Numbers

4.4.1 Connector Layout

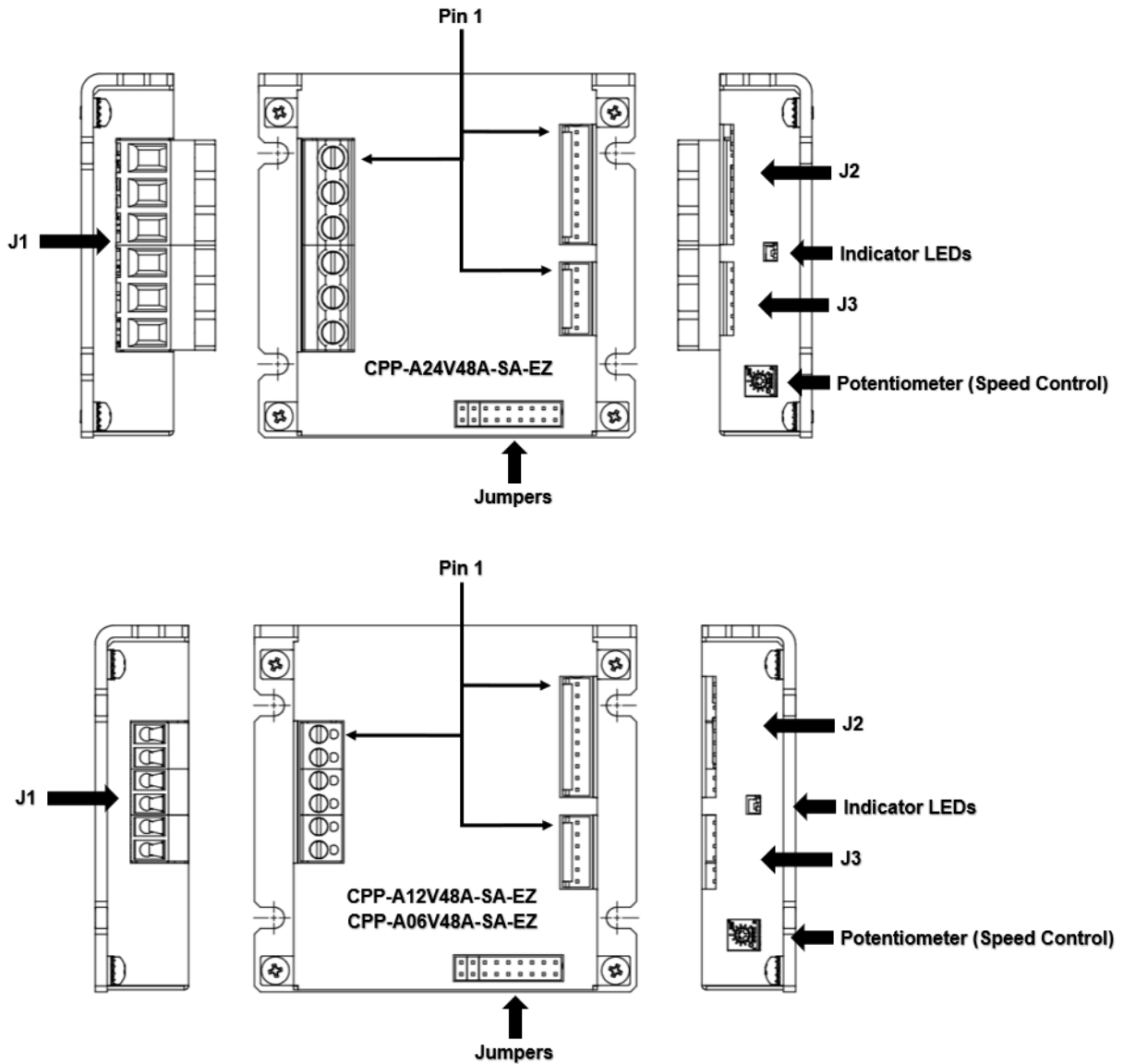

Figure 6: Drive Connector Layouts

4.4.2 J1 Supply and Motor Connector Pinout

Pin #	Name	I/O	Description
1	GND	Input	DC Power Input – Power supply return
2	Power	Input	DC Power Input – Power supply
3	PE	-	Connected to drive chassis
4	A / A+	Output	BLDC Phase A / Stepper Phase A+ / PMDC +
5	B / A-	Output	BLDC Phase B / Stepper Phase A- / PMDC -
6	C / B+	Output	BLDC Phase C / Stepper Phase B+

4.4.3 J2 I/O Connector Pinout

Pin #	Name	I/O	Description
1	Frame	-	Connected to drive chassis
2	An In	Input	Analog input for speed control.
3	Enable	Input	Enable; Digital input.
4	Tach Out	Output	Tach; Digital output for motor speed (pulse train)
5	Fault Out	Output	Fault; Digital output.
6	+5V _{OUT}	Output	+5 Volts DC Power; Internally generated.
7	NC	-	Not used.
8	DIR	Input	Direction; Digital input.
9	Brake	Input	Brake; Digital input.
10	GND	-	Digital Ground; Return for digital I/O pins.

4.4.4 J3 Hall and Tach or Encoder Connector Pinout

Pin #	Name	I/O	Description
1	Hall 1	Input	Hall Signal A; Internal pull up to +3.3 Volts
2	Hall 2	Input	Hall Signal B; Internal pull up to +3.3 Volts
3	Hall 3	Input	Hall Signal C; Internal pull up to +3.3 Volts
4	Tach In	Input	Encoder Signal; +5 Volts digital pulse train
5	+5V _{OUT}	Output	+5 Volts DC Power; Internally generated.
6	GND	-	Digital Ground; Return for encoder signals.

5 Connecting Power & Motors

5.1 Power supply & BLDC Connections

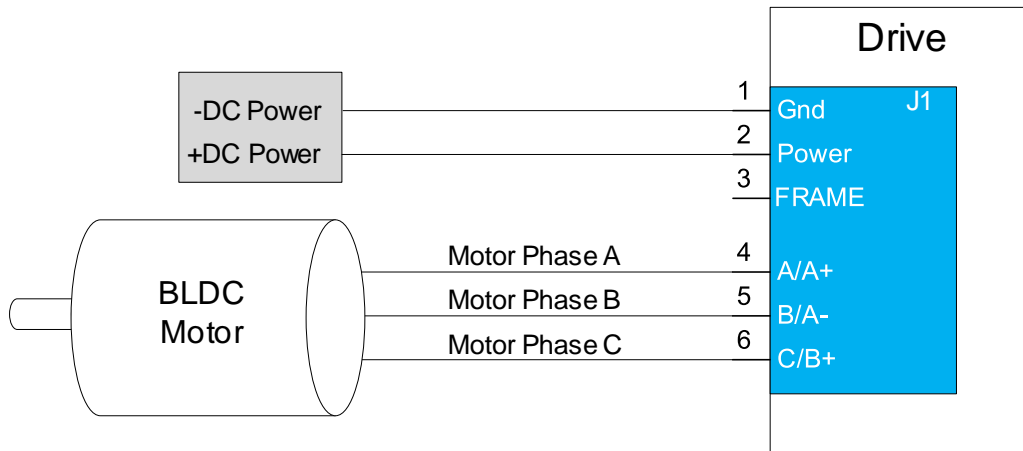

Figure 7: Power Supply & Motor Connections to EZ Drive

6 Connecting Motor Feedback Devices

6.1 Feedback Connections

6.1.1 Hall & Tach/Encoder Sensor Connections

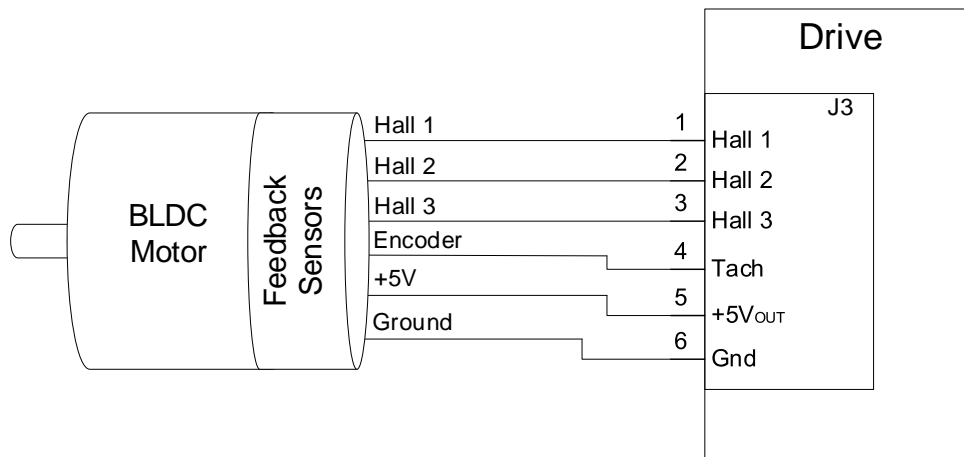

Figure 8: Feedback Sensor Connections to EZ Drive

6.1.2 Hall Sensor Signal Input Circuit

The Hall sensor inputs are limited to +3.3V logic levels. The drive supplied +5V bus can be used to power the motor's hall sensors.

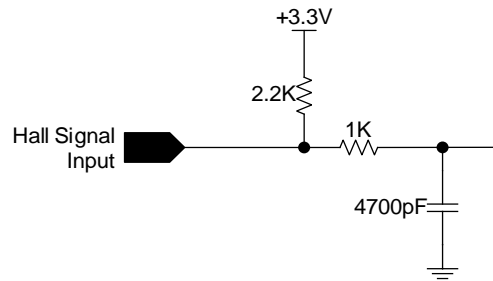

Figure 9: Hall Sensor Input Circuit

6.1.3 Digital Tach/Encoder Input Circuit

The tach input is limited to +5V logic levels. The drive supplied +5V bus can be used to power the motor's encoder sensor (if applicable).

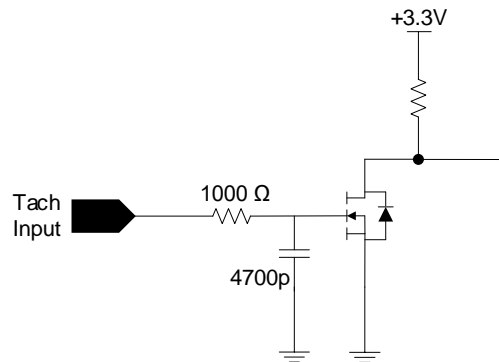

Figure 10: Tach/Encoder Input Circuit

7 Connecting I/O

7.1 I/O Functional Description

I/O Pin Name	Type	Functional Description
Frame	-	Chassis / frame connection.
Analog IN	Analog Input	0 to +10V input signal for speed command from external source.
Enable	Digital Input	Input which enables the drive when an active low signal is applied and disables the drive when a high signal is applied. The signal needs to be kept low for the drive to remain enabled. In case of any drive interruptions or faults, this input should be toggled from high to active low to re-enable the drive.
Direction	Digital Input	When the input signal is active low, it reverses the speed command. This in turn changes the direction of motor rotation.
Brake	Digital Input	Input pin which dynamically brakes the motor when it's active low.
Tach_OUT	Digital Output	Output pulse train with frequency that is proportional to the motor speed. Hall mode: output is XNOR of hall signals Tach mode: output is pass thru of digital tach (or encoder) input See section 7.5 for calculation details.
Fault	Digital Output	Asserts low (sink) when the drive is in a faulted state.
+5 Vout	Output	Internally generated +5V.
Ground	-	Referenced to supply ground.

7.2 I/O Connections

7.2.1 I/O Connections for Internal Speed Control Operation

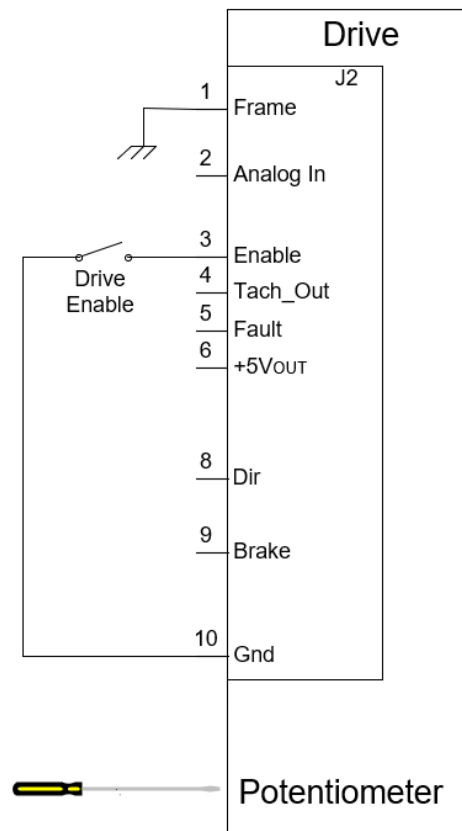

Figure 11: Minimum I/O Connections for Internal Speed Control Operation

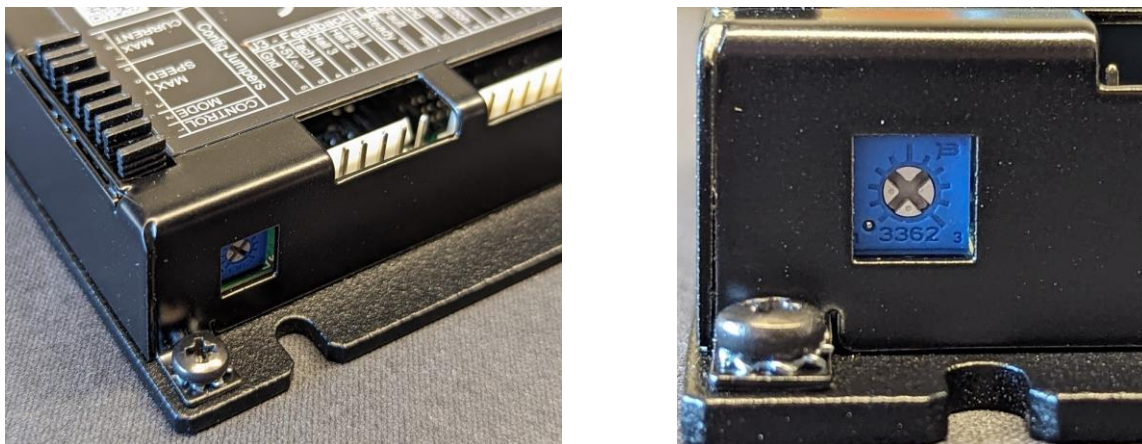

Figure 12: Potentiometer Location

Internal speed control operation allows for quick out of the box operation with minimal interface. The enable input needs to be pulled low to GND, and the potentiometer can then be rotated CW to turn on the motor and increase speed. A standard or Phillips screwdriver can be used to operate the potentiometer.

7.2.2 Standard I/O Connections

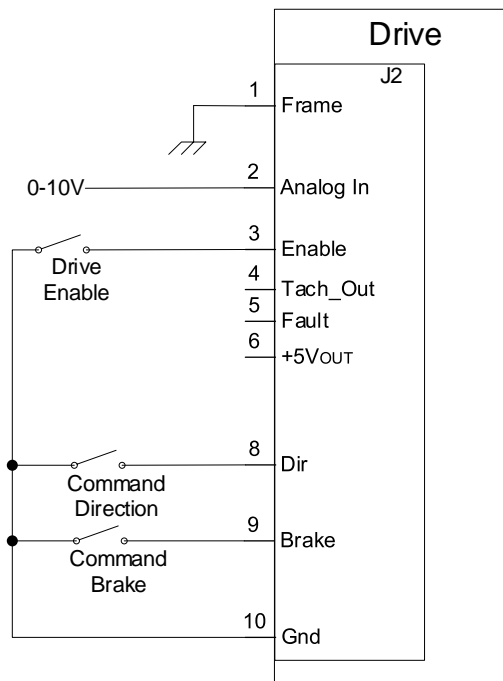

Figure 13: Standard I/O Connections

Figure 13 shows a standard configuration where switches can be used to operate the enable, direction and brake command inputs. An analog voltage of 0-10V can be used at pin 2 for speed control.

7.3 Digital Inputs and Outputs

7.3.1 Digital Input Circuit

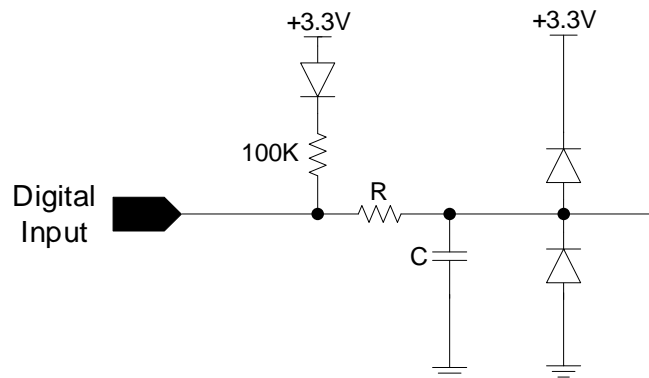

Figure 14: Digital Input Circuit

7.3.2 Digital Output Circuit

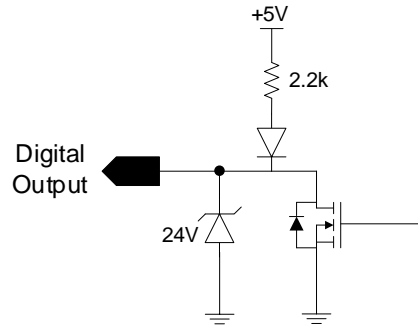

Figure 15: Digital Output Circuit

7.4 Analog Inputs and Outputs

7.4.1 Analog Input Circuit

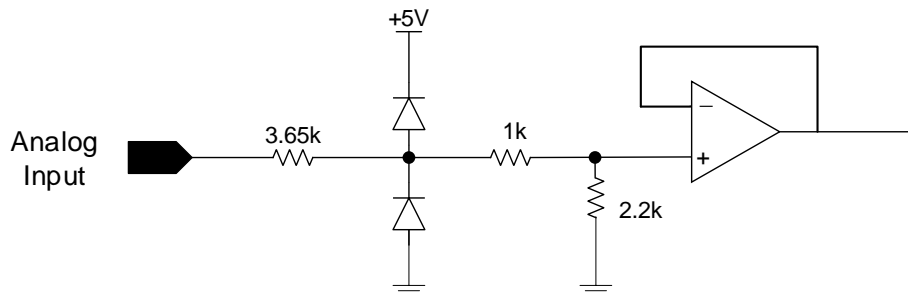

Figure 16: Analog Input Circuit (Speed Control)

7.5 Tach Output Speed Calculation

7.5.1 Hall Mode Speed Calculation

$$\text{Speed (RPM)} = 40 * \text{Freq.} / \text{Poles}$$

Freq: frequency in Hz of pulse train on tach output
Poles: number of motor poles (not pole pairs)

Example: RPX40-250V24

Poles: 14

Measured Frequency on tach output: 1000 Hz

Calculated speed: 2857 RPM

7.5.2 Tach Mode Speed Calculation

$$\text{Speed (RPM)} = 60 * \text{Freq.} / \text{Lines}$$

Freq: frequency in Hz of pulse train on tach output
Poles: number of tach (or encoder) lines

Example: RPX40-250V24

Lines: 2048

Measured Frequency on tach output: 7000 Hz

Calculated speed: 205 RPM

8 User Settings

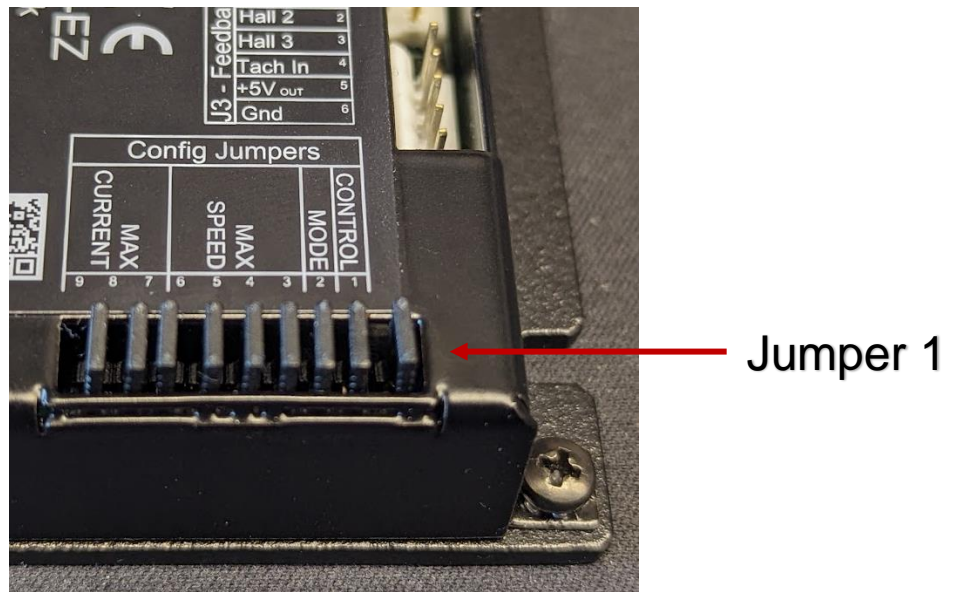

Figure 17: Jumpers for User Settings

Jumper 1: Speed Control Mode	ON: Speed control with potentiometer OFF: Speed control with external analog voltage*
Jumper 2: Feedback Mode	ON: Hall mode OFF: Tach mode
Jumpers 3 - 6: User Max Speed Setting	Max Speed Setting, see section 8.1.1 for details
Jumpers 7 - 9: User Max Current Setting	Max Current Setting, see section 8.1.2 for details

* For external analog speed control, the potentiometer should be dialed CCW to zero.

8.1.1 User Max Speed Setting

Jumper*				Hall Mode Max Speed (RPM)			Tach Mode Max Speed (RPM)		
6	5	4	3	4 Pole	8 Pole	14 Pole	1000 Lines	2048 Lines	5000 Lines
1	1	1	1	1000	500	286	120	60	24
1	1	1	0	2000	1000	571	150	70	30
1	1	0	1	3000	1500	857	180	90	36
1	1	0	0	4000	2000	1143	210	100	42
1	0	1	1	5000	2500	1429	240	120	48
1	0	1	0	6000	3000	1714	270	130	54
1	0	0	1	7000	3500	2000	300	150	60
1	0	0	0	8000	4000	2286	330	160	66
0	1	1	1	9000	4500	2571	360	180	72
0	1	1	0	10000	5000	2857	390	190	78
0	1	0	1	11000	5500	3143	420	200	84
0	1	0	0	12000	6000	3429	450	225	90
0	0	1	1	13000	6500	3714	480	230	96
0	0	1	0	14000	7000	4000	510	250	102
0	0	0	1	15000	7500	4286	540	260	108
0	0	0	0	18000	9000	5143	600	290	120

*1 = Jumper present, 0 = Jumper removed

- In all cases, the minimum speed the drive can control is 150 RPM.
- New jumper settings are not applied until drive enable has been toggled.

8.1.2 User Max Current Setting

Jumper*			Max Current (A)		
9	8	7	High	Med	Low
1	1	1	3	1.5	0.75
1	1	0	6	3	1.5
1	0	1	9	4.5	2.25
1	0	0	12	6	3
0	1	1	15	7.5	3.75
0	1	0	18	9	4.5
0	0	1	21	10.5	5.25
0	0	0	24	12	6

*1 = Jumper present, 0 = Jumper removed

- New jumper settings are not applied until drive enable has been toggled.

9 First Time Operation

To get started, proceed as follows:

1. Connect I/O, motor phase and feedback wires to the drive. Make sure the Enable input is in the OFF position (open or pulled high).
2. Supply required power to the drive (within the voltage and current range as specified in section 3 to operate the motor).
3. Ensure that the green LED is ON, and the red LED is OFF.
4. Ensure that the potentiometer is turned all the way down (CCW), or that the analog input is set to zero.
5. Enable drive by pulling Enable input low, confirm the red LED is not indicating any faults.
6. Increase the potentiometer (turn CW) or increase the input voltage to begin rotating the motor. The TACH output can be monitored to track speed.
7. Jumpers for max speed & current can be removed (and/or replaced) based on application requirements. **New jumper settings are not applied until drive enable has been toggled.**

If the drive does not function, refer to Troubleshooting in section 10.

10 Troubleshooting

If the drive does not function as expected, check the following parameters:

- Input voltage is within drive and motor range.
- Motor and I/O connections are wired correctly to the drive.

10.1 Status LED (Red) Fault Codes

Fault	LED Flash Code	Fault Output	Result	Cause	Recovery
No Faults	OFF	OFF	-	-	-
User Max Current Limit	Flicker	No Change	-	Max current limit set by user has been reached.	-
Overcurrent	1	ON	Drive is disabled until enable input is toggled.	Output current was detected as too high.	Check motor wires for any short conditions.
Over-Voltage	2	ON	Drive is disabled until enable input is toggled.	Drive supply voltage is above the operational limit.	Verify voltage of power supply.
Under-Voltage	3	ON	Drive is disabled until enable input is toggled.	Drive supply voltage is below the operational limit. Could also be caused by high current at lower voltages.	Verify voltage of power supply.
Over-Temperature	4	ON	Drive is disabled until enable input is toggled.	Internal drive PCB temperature has exceeded the operational limit (90 DEGC).	Disconnect power from the drive for 60 seconds and allow for PCB to cool. Then re-apply power to drive.
Locked Rotor, Feedback	5	ON	Drive is disabled until enable input is toggled.	- Hall or digital tach signal are missing or incorrect. - Rotor is locked (not moving).	- Verify hall / commutation signals are present and working correctly. - Verify digital tach or encoder signal is present and working correctly.
System Fault	6	ON	Drive is disabled until enable input is toggled.	Processor fault.	Disconnect power from the drive for 30 seconds for drive to reset and internal components to discharge. Then re-apply power to drive.

10.2 Power LED (Green)

Flash Code	Description	Possible Cause	Result	Recovery Method
ON	Power Indicator	Drive is powered.	Required for drive to operate.	N/A
OFF	Power Indicator	Drive is not powered.	Drive will not operate.	<ul style="list-style-type: none">• Apply power to power input of drive.• Verify input power is within acceptable range.• Check wires for possible short circuit.

