

Solutions in motion

**EAD**<sup>TM</sup> **motors**  
Eastern Air Devices Inc.

# Linear Actuators and Stepping Motors

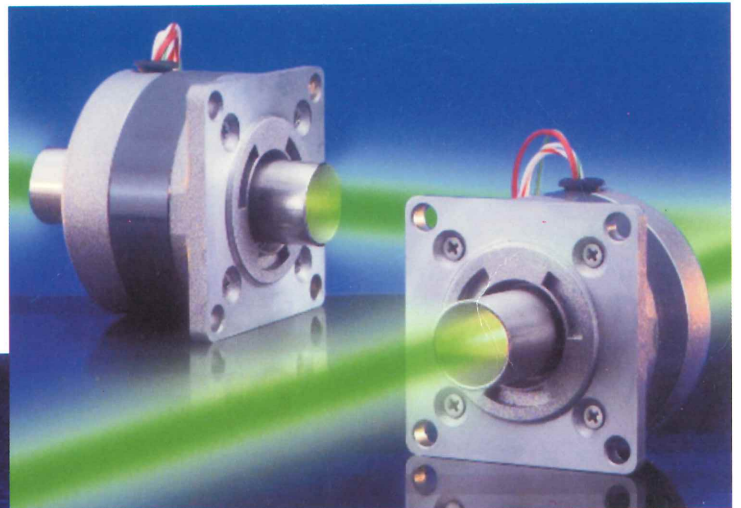

**Custom designs  
available!**

# EADmotors: High-Performance Solutions

## EADmotors

Since 1942, EADmotors has been manufacturing high-performance rotating products for industry.

We have broad experience designing and producing motors, blowers, and fans that meet extremely precise engineering requirements. We are capable of solving difficult design problems involving motion technology.

## Achieving Your Goals

If your company is involved in producing high-performance products such as instruments, satellite tracking systems, control products, etc., EADmotors can provide valuable help. We believe the key to achieving your performance goals is working together. With our strong engineering capabilities, we can work with you to develop precision motion products to meet your most exacting requirements.

## Stepping Motors

For over 25 years, EADmotors has designed stepping motors for a wide range of applications. EAD stepping motors have been used on a variety of products in diverse applications such as packaging,

semiconductor handling and testing, antenna positioning, laboratory equipment, and even electric braking systems for railway cars. EAD stepping motors are known throughout the industry for high quality, long life, and unparalleled consistency.

## Linear Actuators

EADmotors digital linear actuators are based on modified hybrid stepping motors that incorporate an integral nut assembly and precision lead screw design. They are extremely reliable devices that provide a simple and efficient method of creating a linear positioning system. EADmotors linear actuators are available in a variety of sizes from 17 through 42 frame. These precision devices are capable of producing a linear force of up to 700 pounds and resolution up to 0.000125" per 1.8° step.

Conventional designs feature internal rotating nuts made from SAE 660 bearing bronze. The *DuraPlus* series, available in both the L1, L2, and L3 frames, features a precision stainless steel shaft with low friction internal nuts made of a variety of engineered polymers. The *DuraPlus* series is the latest advance in integrated linear motion yielding both long life and smooth, quiet operation.

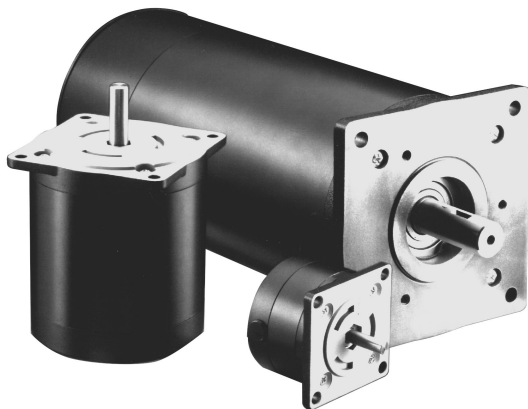

## Table of Contents

Solutions to Problems ...	2
Other Products in Motion .....	3
Rotary Hybrid Stepping Motors	
Size 17 Conventional.....	4
Size 17 High Torque.....	6
Size 23 Conventional.....	8
Size 23 High Torque 1.8° .	10
Size 23 High Torque 0.9° .	12
Size 34 Conventional.....	14
Size 34 High Torque.....	16
Size 42 Conventional.....	18
Linear Actuators	
Size 17 Conventional.....	20
Size L1 <i>DuraPlus</i>	
High Torque.....	22
Size 23 Conventional.....	24
Size L2 <i>DuraPlus</i>	
High Torque.....	26
Size 34 Conventional.....	28
Size L3 <i>DuraPlus</i>	
High Torque.....	30
72 RPM AC Synchronous	
Sizes 23, 34, 42.....	32
VR and PM Stepping Motors	
Sizes 11, 15, 20.....	34
Hybrid Motor	
Connection Diagrams ...	38

Solutions in motion



# Solutions to Problems

Think of EADmotors as the company that gives you solutions. We are capable of supplying auxiliary components and hardware to improve the performance and profitability of your products. We'd like to be a member of your team, working with you to produce products of the highest quality at minimum cost.

## Quick Delivery for Custom Products

EADmotors specializes in meeting individual customer requirements. We have developed the ability to quickly design and manufacture custom products and modified standards. Some typical examples of the type of modifications we do every day are:

- Connectors
- Shielded cables
- Special shafts
- Custom end caps and mounting configurations
- Custom windings to optimize performance
- Special packaging for harsh environments
- Precision tolerances

## Other Products in Motion

### Brushless DC Servo Motors

EADmotors offers a full line of brushless DC servo motors from size 17 through size 42. Our servo motors feature high energy neodymium magnets for high torque in a compact package. EAD servo motors offer high speed and extremely smooth and precise motion. They are fully compatible with industry standard analog and digital servo amplifiers. Our servo motors operate at high speed and provide extremely smooth and precise motion when stepping motor technology has reached its limits. Typical applications include high speed inspection systems, semiconductor handling equipment, document sorting equipment, and medical systems.

### Axial Fans

EADmotors manufactures a broad line of vane axial, tube axial, and axial fans. They encompass a wide range of air volumes at low to relatively high pressures. Designed for maximum efficiency at minimum input, these high-performance fans offer exceptionally long life and reliability. Quiet, smooth-running ball bearings eliminate the need for maintenance and lubrication.

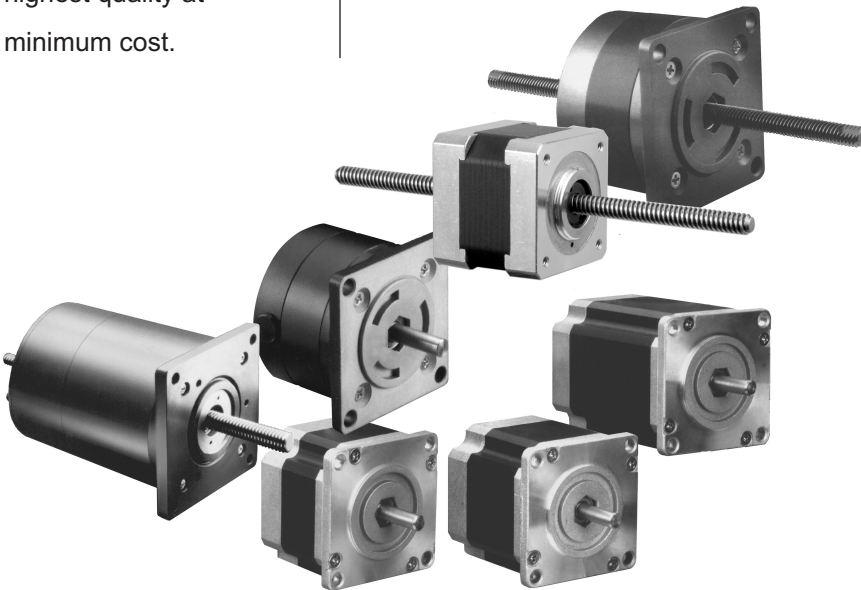

*Solutions in motion*

**EAD**<sup>™</sup>**motors**  
Eastern Air Devices Inc.



# Other Products in Motion

## Centrifugal Blowers

EADmotors centrifugal blowers are known for quiet, reliable operation. Made in single, double, and inverted styles, they deliver up to 600 CFM airflow. The AC blowers have near-constant speed permanent split capacitor motors. Brushless DC models operate at fixed or variable speed.

## Synchronous Motors

Synchronous motors run at an exact speed. The speed will not vary with load or voltage. We make hysteresis and reluctance types in a wide range of frame sizes. EAD hysteresis-synchronous motors develop smooth, constant starting and accelerating torques. They synchronize any load within their torque rating—regardless of inertia.

EAD reluctance-synchronous motors function at constant speeds—and cost very little more than standard induction motors.

## Induction Motors

In single and 3-phase models, EAD induction motors are designed for a wide range of commercial and military applications. For low starting torque applications, permanent-split capacitor types offer higher efficiency and a higher power factor than other designs. Capacitor start and split phase motors are used when a high starting torque is required. EADmotors manufactures both high and low slip permanent split capacitor motors to meet a wide range of application requirements.

## Torque Motors

They may involve either static or dynamic forces. Applications may require smooth, moderate accelerating torque and low speed with speed ranges from near synchronous to zero.

## Stator/Rotor Sets

EADmotors provides frameless versions of all of our designs. Stator/rotor sets offer the advantage of eliminating component parts in a system such as redundant bearings and couplings. They also allow systems to be smaller and more reliable as possible failure modes are eliminated at the design stage. Contact us for more information about how stator/rotor sets can make your products more competitive.

In addition to stepping motors, EADmotors manufactures a wide range of other types of motors and controls as well as blowers and fans.



*Solutions in motion*



# Rotary Hybrid Stepping Motor 1.8°

SIZE  
**17**  
**1.57"**  
SQ

## Conventional

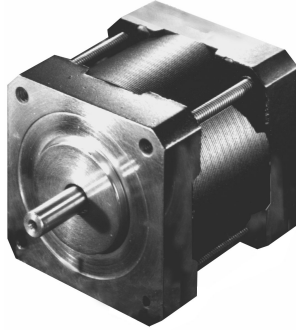

EADmotors Size 17 hybrid DC stepping motors are precision bi-directional devices with position accuracy of  $\pm 5\%$  non-cumulative.

Motors are totally enclosed with permanently lubricated ball bearings.

Standard motors have 4 or 6 leads. Motors with 5 or 8 leads can be furnished to meet existing applications.

EADmotors specializes in meeting the individual requirements of each application and offers engineering assistance for your design requirements.

### Electrical Ratings

Model Number	Number of Leads	Unipolar Connection					Bipolar Connection					Rotor Inertia (oz-in-sec <sup>2</sup> )	Weight (ounces)
		Phase Voltage (VDC)	Phase Current (amps)	Phase Resistance (ohms)	Phase Inductance (mH)	Holding Torque (oz-in)	Phase Voltage (VDC)	Phase Current (amps)	Phase Resistance (ohms)	Phase Inductance (mH)	Holding Torque (oz-in)		
ZB17GBK-10	6	4.00	0.95	4.20	2.9	13.9	5.60	0.67	8.40	11.6	19	0.00024	7
ZB17GBK-11	6	6.00	0.63	9.60	4.90	13.9	8.50	0.45	19.20	19.60	19		
ZB17GBK-12	6	12.00	0.32	38.40	22	13.9	17.00	0.23	76.80	88.0	19		
ZB17GBK-200	4						1.90	2.00	0.95	1.40	19		
ZB17EBK-10	6	4.00	1.10	3.50	2.50	19	5.60	0.78	7.00	10.00	24.5	0.00035	7.7
ZB17EBK-11	6	6.00	0.80	7.50	5.30	19	8.50	0.57	15.00	21.20	24.5		
ZB17EBK-12	6	12.00	0.40	30.00	27.3	19	17.00	0.28	60.00	109.2	24.5		
ZB17EBK-200	4						2.40	2.00	1.20	2.40	24.5		
ZB17BBK-10	6	4.00	1.20	3.30	3.2	28.3	5.90	0.85	6.60	12.8	35	0.00051	10.6
ZB17BBK-11	6	6.00	0.92	6.50	6.0	28.3	8.50	0.65	13.00	24.0	35		
ZB17BBK-12	6	12.00	0.46	36.00	23.5	28.3	17.00	0.33	52.00	94.0	35		
ZB17BBK-200	4						2.75	2.00	1.38	2.70	35		

Solutions in motion



# Rotary Hybrid Stepping Motor 1.8°

Conventional

SIZE  
**17**  
**1.57"**  
SQ

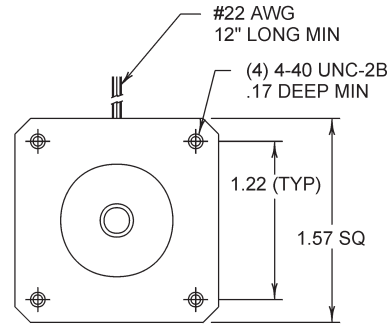
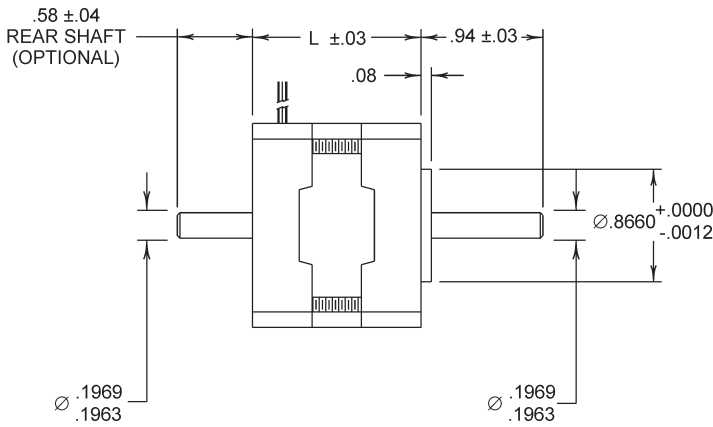

## Size 17

Model Series	Dimension "L" (inches)
ZB17GBK	1.30
ZB17EBK	1.54
ZB17BBK	1.85

See page 38 for Connection Diagrams.

For the rear shaft option, use the suffix "R" (for example, ZB17GBK-10R).

## Pullout Torque Speed Curves

Typical Unipolar Performance (6 Lead Motor): Constant Voltage Drive (L/R), 2 Phase On

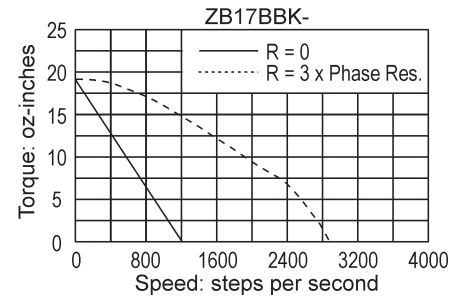
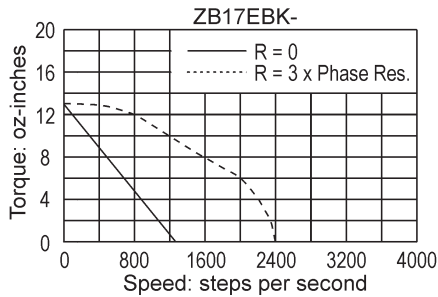
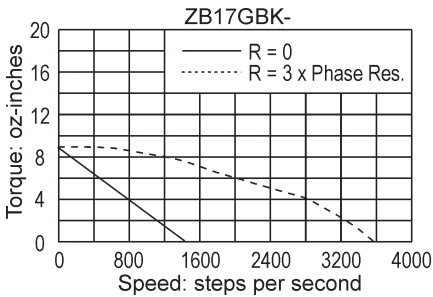

Typical Bipolar Performance: 40 VDC Power Supply, 2 Amp/Phase

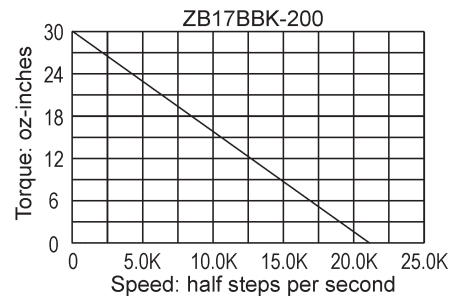
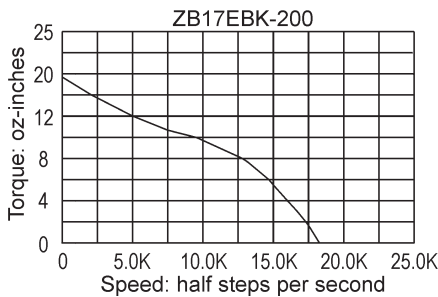
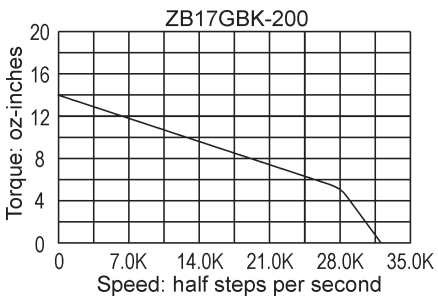

Solutions in motion



SIZE  
**17**  
**1.65"**  
SQ

# Rotary Hybrid Stepping Motor 1.8°

## High Torque

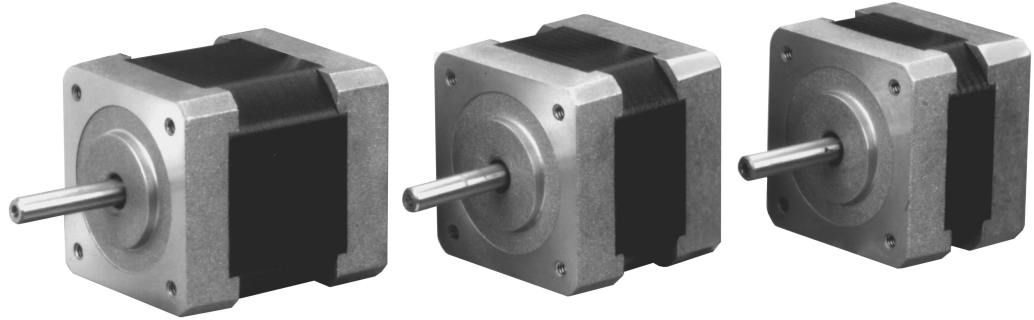

EADmotors Size 17 hybrid DC stepping motors are precision bi-directional devices with position accuracy of  $\pm 6\%$  non-cumulative.

Motors are totally enclosed with permanently lubricated ball bearings.

Standard motors have 4 or 6 leads. Motors with 5 or 8 leads can be furnished to meet existing applications.

EADmotors specializes in meeting the individual requirements of each application and offers engineering assistance for your design requirements.

### Electrical Ratings

Model Number	Number of Leads	Unipolar Connection					Bipolar Connection					Holding Torque (oz-in)	Rotor Inertia (oz-in-sec <sup>2</sup> )	Weight (ounces)
		Phase Voltage (VDC)	Phase Current (amps)	Phase Resistance (ohms)	Phase Inductance (mH)	Holding Torque (oz-in)	Phase Voltage (VDC)	Phase Current (amps)	Phase Resistance (ohms)	Phase Inductance (mH)				
LH1713-10	6	4.00	0.95	4.20	2.5	22.2	5.60	0.67	8.40	10.0	29.0	0.00053	7.0	
LH1713-11	6	6.00	0.62	9.60	5.8	22.2	8.50	0.44	19.2	23.2	29.0			
LH1713-12	6	12.00	0.31	38.5	23	22.2	17.00	0.22	77	92	29.0			
LH1713-14	6	9.60	0.40	24.0	15.0	22.2	13.6	0.28	48.0	60	29.0			
LH1713-M100	4						3.8	1.00	3.8	4.8	29.0			
LH1713-M150	4						2.8	1.5	1.90	2.3	29.0			
LH1713-M200	4						1.9	2.0	0.95	1.2	29.0			
LH1715-10	6	4.00	1.2	3.3	3.2	36.1	5.60	0.85	6.60	12.8	47.0	0.00081	9.0	
LH1715-11	6	6.00	0.80	7.50	7.0	36.1	8.50	0.57	15.0	28	47.0			
LH1715-12	6	12.00	0.40	30.0	28	36.1	17.00	0.28	60.0	112	47.0			
LH1715-13	6	24.0	0.20	120	112	36.1	33.9	0.14	240	448	47.0			
LH1715-M100	4						4.7	1.00	4.7	9.1	47.0			
LH1715-M150	4						3.6	1.5	2.4	4.7	47.0			
LH1715-M200	4						2.4	2.0	1.2	2.3	47.0			
LH1719-10	6	4.00	1.20	3.30	2.8	44.4	5.7	0.85	6.60	11.2	58.0	0.00106	11.8	
LH1719-11	6	6.00	0.80	7.50	7.0	44.4	8.50	0.57	15.0	28	58.0			
LH1719-12	6	12.00	0.40	30.0	28	44.4	17.00	0.28	60.0	112	58.0			
LH1719-13	6	24.0	0.20	120	112	44.4	33.9	0.14	240	448	58.0			
LH1719-M100	4						5.2	1.00	5.2	8.4	58.0			
LH1719-M150	4						3.7	1.5	2.5	4.3	58.0			
LH1719-M200	4						2.4	2.0	1.2	2.2	58.0			

Solutions in motion



# Rotary Hybrid Stepping Motor 1.8°

High Torque

SIZE  
**17**  
1.65"  
SQ

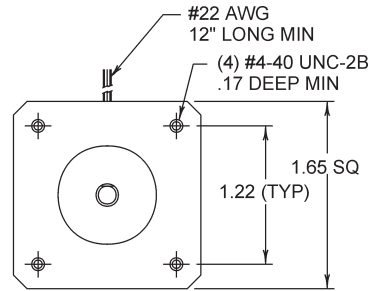
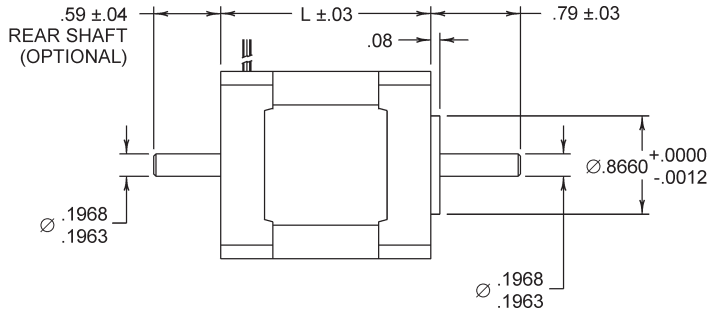

## Size 17

Model Series	Dimension "L" (inches)
LH1713	1.28
LH1715	1.52
LH1719	1.85

See page 38 for Connection Diagrams.

For the rear shaft extension, use the suffix "R" (for example, LH1713-10R).

## Pullout Torque Speed Curves

### Typical Unipolar Performance (6 Lead Motor): Constant Voltage Drive (L/R), 2 Phase On

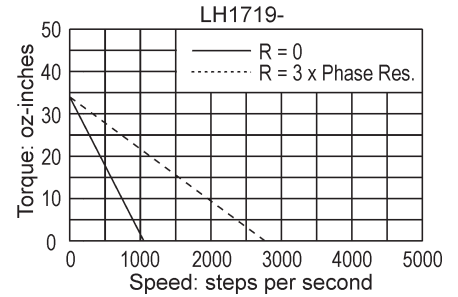
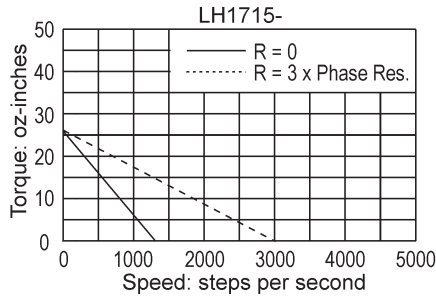
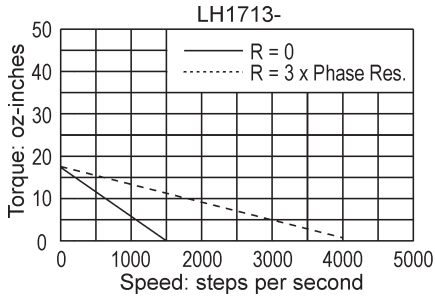

### Typical Bipolar Performance: 40 VDC Power Supply, 2 Amps/Phase

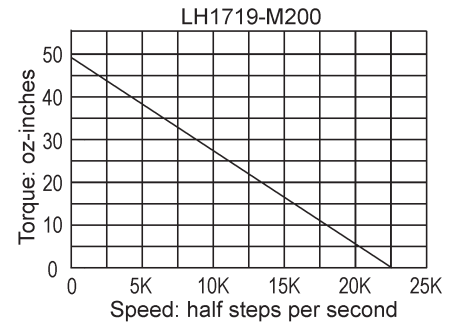
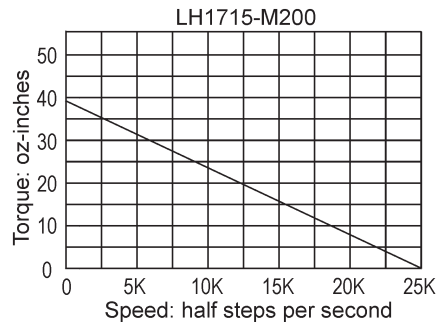
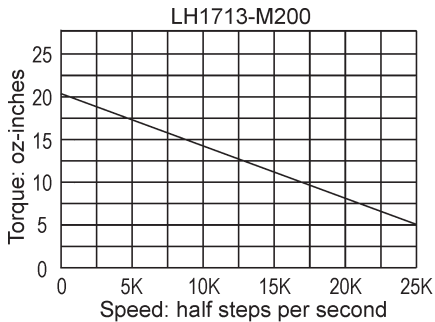

Solutions in motion





# Rotary Hybrid Stepping Motor 1.8°

SIZE  
**23**  
2.25"  
DIA

## Conventional



EADmotors Size 23 hybrid DC stepping motors are precision bi-directional devices with position accuracy of ±3% non-cumulative.

Motors are totally enclosed with permanently lubricated ball bearings.

Standard motors have 4 or 6 leads. Motors with 5 or 8 leads can be furnished to meet existing applications. These motors are also available in 5 and 7.5 degree step angles.

EADmotors specializes in meeting the individual requirements of each application and offers engineering assistance for your design requirements.

## Electrical Ratings

Model Number	Number of Leads	Unipolar Connection					Bipolar Connection					Rotor Inertia (oz-in-sec <sup>2</sup> )	Weight (ounces)
		Phase Voltage (VDC)	Phase Current (amps)	Phase Resistance (ohms)	Phase Inductance (mH)	Holding Torque (oz-in)	Phase Voltage (VDC)	Phase Current (amps)	Phase Resistance (ohms)	Phase Inductance (mH)	Holding Torque (oz-in)		
LA23GCK-209	6	1.40	5.90	0.235	0.3	38.5	1.98	4.18	0.47	1.0	48	0.00081	14
LA23GCK-210	6	4.00	1.54	2.60	3.2	38.5	5.70	1.10	5.20	12.7	48		
LA23GCK-211	6	6.00	1.20	5.00	5.4	38.5	8.50	0.85	10.00	21.6	48		
LA23GCK-212	6	12.00	0.60	20.00	21.6	38.5	17.00	0.42	40.00	86.4	48		
LA23GCK-213	6	24.00	0.30	80.00	81.2	38.5	34.00	0.21	160.00	324.6	48		
LA23GCK-M100	4						6.0	1.00	5.90	16.9	48		
LA23GCK-M200	4						3.0	2.00	1.50	4.2	48		
LA23GCK-M300	4						2.0	3.00	0.66	1.9	48		
LA23GCK-M400	4						1.5	4.00	0.37	1.1	48		
LA23ECK-3	6	1.40	3.89	0.36	0.6	57.5	2.00	2.78	0.72	2.4	72		
LA23ECK-6	6	3.40	1.55	2.20	4.1	57.5	4.80	1.09	4.40	16.2	72		
LA23ECK-4	6	5.10	1.00	5.10	9.7	57.5	7.20	0.71	10.20	38.9	72		
LA23ECK-11	6	6.00	0.97	6.20	10.6	57.5	8.50	0.68	12.40	42.4	72		
LA23ECK-12	6	12.00	0.48	25.00	41.19	57.5	17.00	0.34	50.00	164.76	72		
LA23ECK-13	6	24.00	0.25	96.00	131.40	57.5	34.00	0.18	192.00	525.60	72		
LA23ECK-M100	4						5.6	1.00	5.6	25.6	72		
LA23ECK-M200	4						2.8	2.00	1.4	6.4	72		
LA23ECK-M300	4						1.9	3.00	0.62	2.8	72		
LA23ECK-M400	4						1.4	4.00	0.35	1.6	72		
LA23BCK-9	6	1.70	4.59	0.37	0.8	120	2.40	3.25	0.74	3.0	150	0.00331	32
LA23BCK-10	6	4.30	1.79	2.40	5.3	120	6.10	1.27	4.80	21.3	150		
LA23BCK-11	6	5.40	1.54	3.50	7.8	120	7.60	1.09	7.00	31.2	150		
LA23BCK-47	6	6.00	1.25	4.80	11.4	120	8.50	0.88	9.60	45.6	150		
LA23BCK-40	6	12.00	0.66	18.20	41.2	120	17.00	0.47	36.40	164.6	150		
LA23BCK-41	6	24.00	0.36	66.00	143.3	120	34.00	0.26	132.00	573.2	150		
LA23BCK-M100	4						7.6	1.00	7.6	35.2	150		
LA23BCK-M200	4						3.8	2.00	1.9	8.8	150		
LA23BCK-M300	4						2.5	3.00	0.84	3.9	150		
LA23BCK-M400	4						1.9	4.00	0.48	2.2	150		
LA23DGK-1	6	2.20	4.58	0.48	1.1	168	3.10	3.23	0.96	4.4	210	0.00497	47
LA23DGK-2	6	3.40	2.83	1.20	2.9	168	4.80	2.00	2.40	11.4	210		
LA23DGK-23	6	6.00	1.76	3.40	8.4	168	8.50	1.25	6.80	33.4	210		
LA23DGK-24	6	12.00	0.75	16.00	39.0	168	17.00	0.53	32.00	156.0	210		
LA23DGK-25	6	24.00	0.44	55.00	117.1	168	34.00	0.31	110.00	468.0	210		
LA23DGK-M200	4						5.3	2.00	2.65	13.2	210		
LA23DGK-M300	4						3.54	3.00	1.18	5.88	210		
LA23DGK-M400	4						2.65	4.00	0.66	3.3	210		

Solutions in motion



# Rotary Hybrid Stepping Motor 1.8°

Conventional

SIZE  
**23**  
2.25"  
DIA

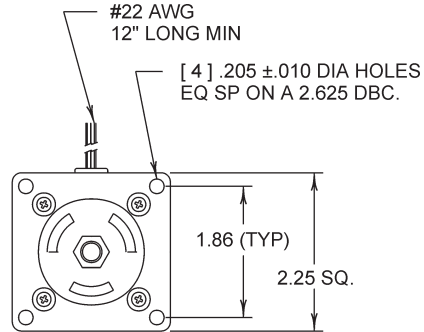
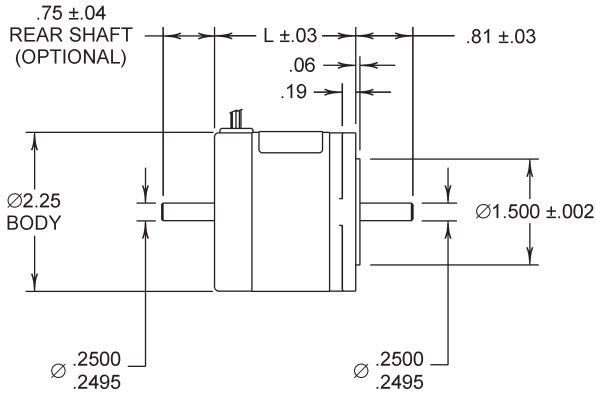

## Size 23

Model Series	Dimension "L" (inches)
LA23GCK	1.60
LA23ECK	2.00
LA23BCK	3.00
LA23DGK	4.00

See page 38 for Connection Diagrams.

For the rear shaft option, use the suffix "R" (for example, LA23GCK-209R).

## Pullout Torque Speed Curves

### Typical Unipolar Performance (6 Lead Motor): Constant Voltage Drive (L/R), 2 Phase On

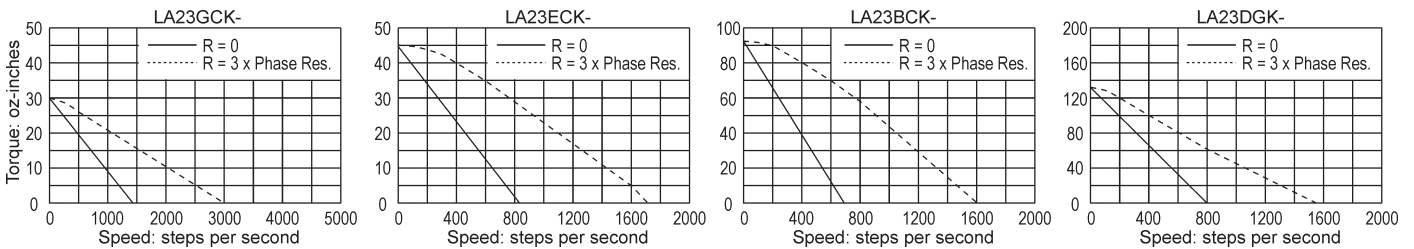

### Typical Bipolar Performance: 40 VDC Power Supply, 2 Amps

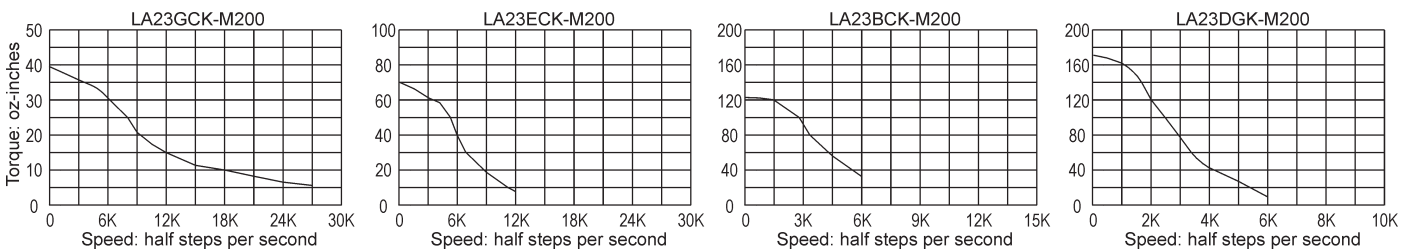

Solutions in motion



SIZE  
**23**  
2.22"  
SQ

# Rotary Hybrid Stepping Motor 1.8°

## High Torque

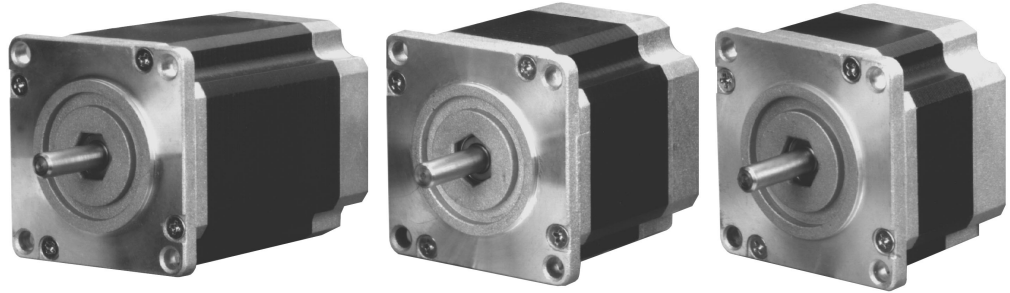

EADmotors Size 23 hybrid DC stepping motors are precision bi-directional devices with position accuracy of ±3% non-cumulative.

Motors are totally enclosed with permanently lubricated ball bearings.

Standard motors have 4 or 6 leads. Motors with 5 or 8 leads can be furnished to meet existing applications.

EADmotors specializes in meeting the individual requirements of each application and offers engineering assistance for your design requirements.

### Electrical Ratings

Model Number	Unipolar Connection						Bipolar Connection						Rotor Inertia (oz-in-sec.)	Weight (ounces)
	Number of Leads	Phase Voltage (VDC)	Phase Current (amps)	Phase Resistance (ohms)	Phase Inductance (mH)	Holding Torque (oz-in)	Phase Voltage (VDC)	Phase Current (amps)	Phase Resistance (ohms)	Phase Inductance (mH)	Holding Torque (oz-in)			
LH2318-05	6	11.90	0.50	23.50	41.4	72	16.8	0.35	47.00	165.6	90	0.002	17	
LH2318-1	6	6.00	1.00	6.00	10.8	72	8.49	0.71	12.00	43.2	90			
LH2318-2	6	3.00	2.00	1.57	2.6	72	4.24	1.41	3.14	10.4	90			
LH2318-3	6	1.80	3.00	0.61	1.0	72	2.55	2.12	1.22	4.0	90			
LH2318-M100	4						5.80	1.00	5.78	20.3	90			
LH2318-M200	4						3.00	2.00	1.50	5.2	90			
LH2318-M300	4						1.80	3.00	0.60	2.0	90			
LH2322-05	6	15.40	0.50	30.90	67.3	120	21.8	0.35	61.80	269.2	150	0.0035	24	
LH2322-1	6	7.60	1.00	7.59	17.7	120	10.8	0.71	15.18	70.8	150			
LH2322-2	6	3.80	2.00	1.91	4.2	120	5.37	1.41	3.82	16.8	150			
LH2322-3	6	2.30	3.00	0.76	1.6	120	3.25	2.12	1.52	6.4	150			
LH2322-M100	4						7.90	1.00	7.92	35.00	150			
LH2322-M200	4						3.80	2.00	1.90	8.60	150			
LH2322-M300	4						2.40	3.00	0.80	3.50	150			
LH2331-05	6	17.90	0.50	35.70	93.8	190	25.3	0.35	71.40	375.2	240	0.0061	37	
LH2331-1	6	9.20	1.00	9.23	22.5	190	13.0	0.71	18.46	90.0	240			
LH2331-2	6	4.50	2.00	2.24	5.2	190	6.36	1.41	4.48	20.8	240			
LH2331-3	6	2.80	3.00	0.92	2.1	190	3.96	2.12	1.84	8.4	240			
LH2331-M100	4						9.10	1.00	9.13	45.4	240			
LH2331-M200	4						4.70	2.00	2.33	11.5	240			
LH2331-M300	4						3.00	3.00	1.00	4.8	240			

Solutions in motion



# Rotary Hybrid Stepping Motor 1.8°

High Torque

SIZE  
**23**  
2.22"  
SQ

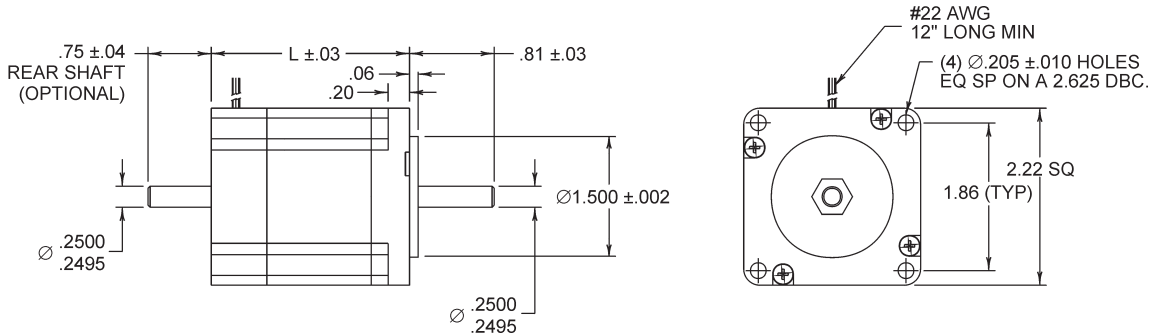

Size 23	
Model Series	Dimension "L" (inches)
LH2318	1.75
LH2322	2.21
LH2331	3.09

See page 38 for Connection Diagrams.  
For the rear shaft option, use the suffix "R" (for example, LH2318-2R).

## Pullout Torque Speed Curves

Typical Unipolar Performance (6 Lead Motor): Constant Voltage Drive (L/R), 2 Phase On

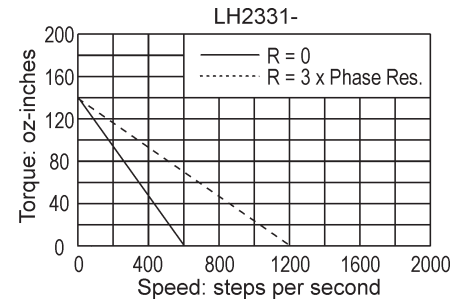
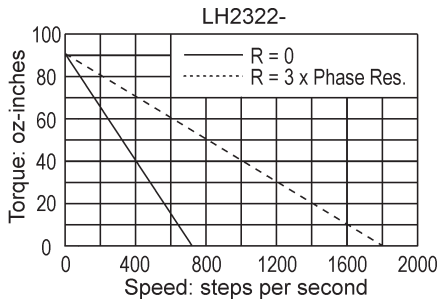
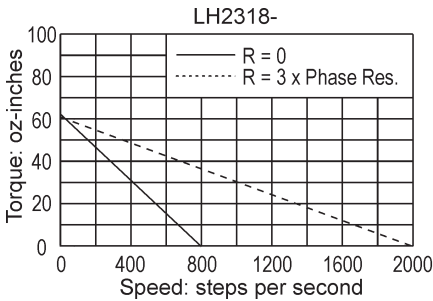

Typical Bipolar Performance: 80 VDC Power Supply, 3 Amps/Phase

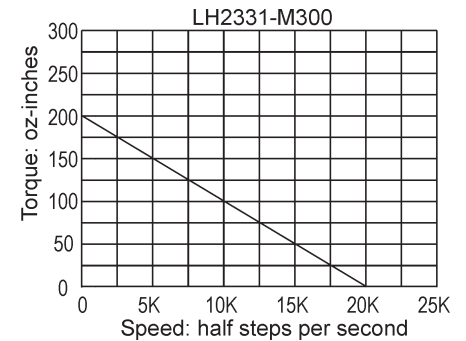
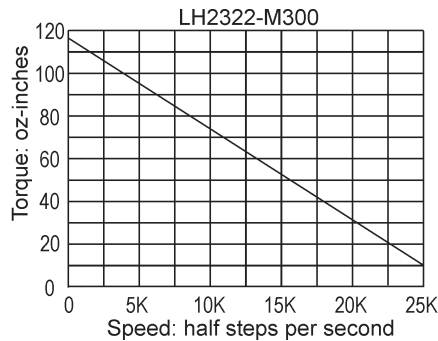
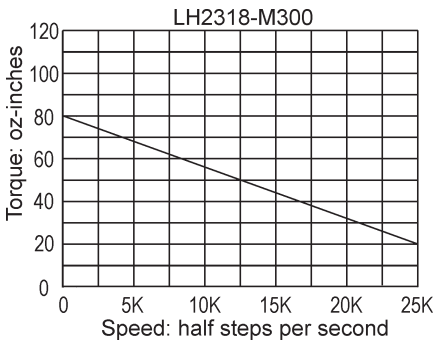

Solutions in motion





# Rotary Hybrid Stepping Motor 0.9°

SIZE  
**23**  
2.22"  
SQ

## High Torque

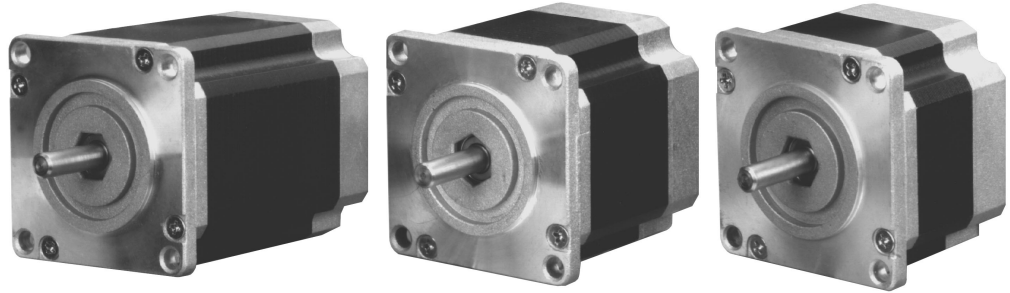

EADmotors Size 23 hybrid DC 0.9° stepping motors are precision bi-directional devices with position accuracy of ±8% non-cumulative.

Motors are totally enclosed with permanently lubricated ball bearings.

Standard motors have 4 or 6 leads. Motors with 5 or 8 leads can be furnished to meet existing applications.

EADmotors specializes in meeting the individual requirements of each application and offers engineering assistance for your design requirements.

## Electrical Ratings

Model Number	Number of Leads	Unipolar Connection					Bipolar Connection					Holding Torque (oz-in)	Rotor Inertia (oz-in-sec <sup>2</sup> )	Weight (ounces)
		Phase Voltage (VDC)	Phase Current (amps)	Phase Resistance (ohms)	Phase Inductance (mH)	Holding Torque (oz-in)	Phase Voltage (VDC)	Phase Current (amps)	Phase Resistance (ohms)	Phase Inductance (mH)				
MH2318-05	6	11.90	0.50	23.50	41.4	72	16.8	0.35	47.00	165.6	90	0.002	17	
MH2318-1	6	6.00	1.00	6.00	10.8	72	8.49	0.71	12.00	43.2	90			
MH2318-2	6	3.00	2.00	1.57	2.6	72	4.24	1.41	3.14	10.4	90			
MH2318-3	6	1.80	3.00	0.61	1.0	72	2.55	2.12	1.22	4.0	90			
MH2318-M100	4						5.80	1.00	5.78	20.3	90			
MH2318-M200	4						3.00	2.00	1.50	5.2	90			
MH2318-M300	4						1.80	3.00	0.60	2.0	90			
MH2322-05	6	15.40	0.50	30.90	67.3	120	21.8	0.35	61.80	269.2	150	0.0035	24	
MH2322-1	6	7.60	1.00	7.59	17.7	120	10.8	0.71	15.18	70.8	150			
MH2322-2	6	3.80	2.00	1.91	4.2	120	5.37	1.41	3.82	16.8	150			
MH2322-3	6	2.30	3.00	0.76	1.6	120	3.25	2.12	1.52	6.4	150			
MH2322-M100	4						7.90	1.00	7.92	35.00	150			
MH2322-M200	4						3.80	2.00	1.90	8.60	150			
MH2322-M300	4						2.40	3.00	0.80	3.50	150			
MH2331-05	6	17.90	0.50	35.70	93.8	190	25.3	0.35	71.40	375.2	240	0.0061	37	
MH2331-1	6	9.20	1.00	9.23	22.5	190	13.0	0.71	18.46	90.0	240			
MH2331-2	6	4.50	2.00	2.24	5.2	190	6.36	1.41	4.48	20.8	240			
MH2331-3	6	2.80	3.00	0.92	2.1	190	3.96	2.12	1.84	8.4	240			
MH2331-M100	4						9.10	1.00	9.13	45.4	240			
MH2331-M200	4						4.70	2.00	2.33	11.5	240			
MH2331-M300	4						3.00	3.00	1.00	4.8	240			

Solutions in motion



# Rotary Hybrid Stepping Motor 0.9°

High Torque

SIZE  
**23**  
2.22"  
SQ

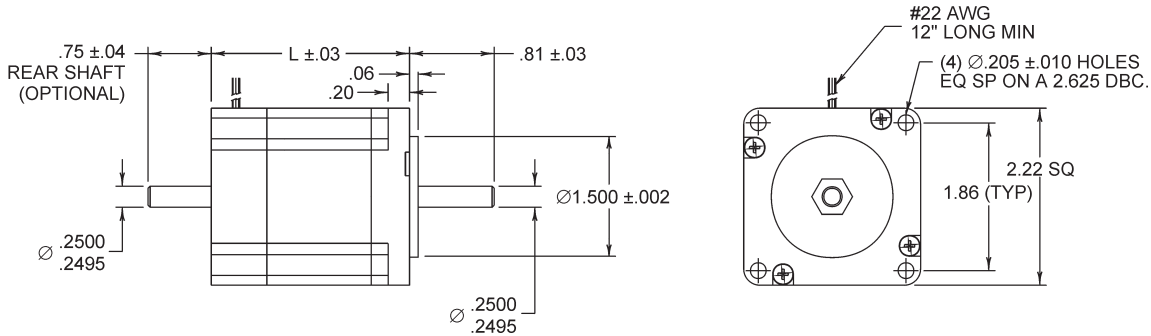

Size 23	
Model Series	Dimension "L" (inches)
MH2318	1.75
MH2322	2.21
MH2331	3.09

See page 38 for Connection Diagrams.  
For the rear shaft option, use the suffix "R" (for example, MH2318-2R).

## Pullout Torque Speed Curves

### Typical Unipolar Performance (6 Lead Motor): Constant Voltage Drive (L/R), 2 Phase On

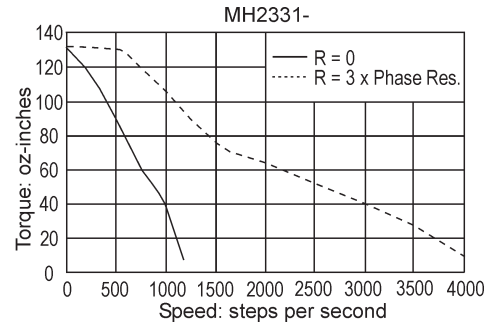
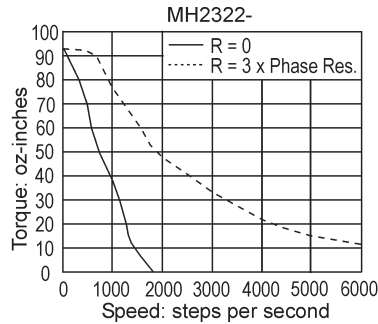
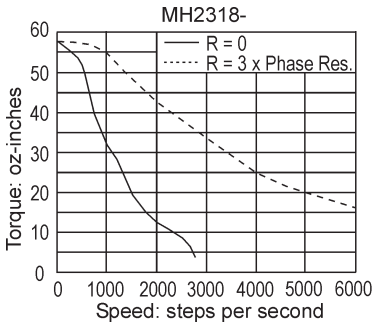

### Typical Bipolar Performance: 80 VDC Power Supply, 3 Amps/Phase

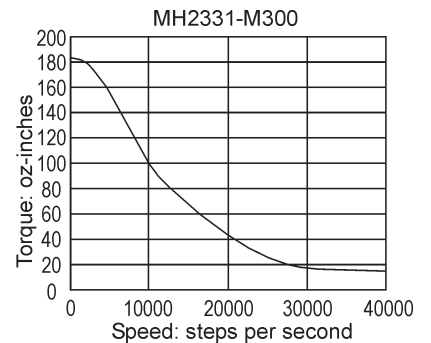
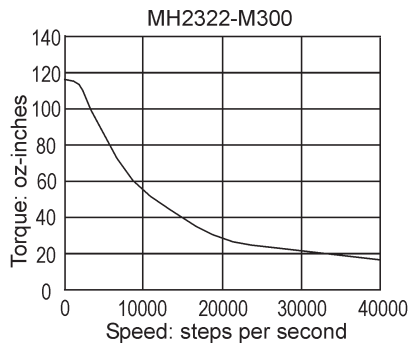
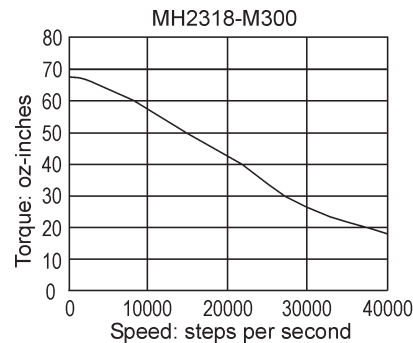

Solutions in motion



SIZE  
**34**  
3.38"  
DIA

# Rotary Hybrid Stepping Motor 1.8°

## Conventional

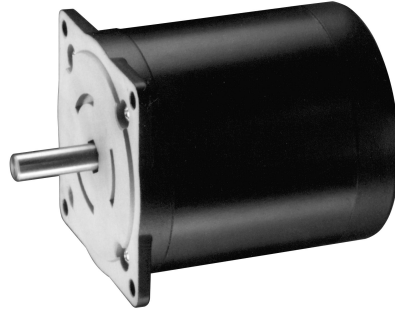

EADmotors Size 34 hybrid DC stepping motors are precision bi-directional devices with position accuracy of  $\pm 3\%$  non-cumulative.

Motors are totally enclosed with permanently lubricated ball bearings.

Standard motors have 4 or 6 leads. Motors with 5 or 8 leads can be furnished to meet existing applications. These motors are also available in 1.875 and 5 degree step angles.

EADmotors specializes in meeting the individual requirements of each application and offers engineering assistance for your design requirements.

### Electrical Ratings

Model Number	Unipolar Connection						Bipolar Connection						Rotor Inertia (oz-in-sec <sup>2</sup> )	Weight (ounces)
	Number of Leads	Phase Voltage (VDC)	Phase Current (amps)	Phase Resistance (ohms)	Phase Inductance (mH)	Holding Torque (oz-in)	Phase Voltage (VDC)	Phase Current (amps)	Phase Resistance (ohms)	Phase Inductance (mH)	Holding Torque (oz-in)			
LA34AGK-1	6	1.70	4.72	0.36	1.62	188	2.4	3.34	0.72	6.48	235	0.0091	48	
LA34AGK-2	6	2.60	3.06	0.85	4.15	188	3.7	2.17	1.70	16.60	235			
LA34AGK-4	6	5.30	1.61	3.30	17.50	188	7.5	1.14	6.60	70.00	235			
LA34AGK-9	6	12.00	0.67	18.00	80.00	188	17.0	0.47	36.00	320.00	235			
LA34AGK-10	6	24.00	0.33	72.00	315.00	188	34.0	0.24	144.00	1260.00	235			
LA34AGK-M200	4						4.4	2.00	2.2	20.4	235			
LA34AGK-M300	4						2.9	3.00	0.96	9.07	235			
LA34AGK-M400	4						2.2	4.00	0.55	5.1	235			
LA34AGK-M600	4						1.5	6.00	0.24	2.27	235			
LA34BJK-1	6	2.50	4.55	0.55	2.75	336	3.5	3.18	1.10	11.00	420			0.0170
LA34BJK-2	6	3.00	4.00	0.75	3.60	336	4.2	2.80	1.50	14.40	420			
LA34BJK-30	6	6.00	2.00	3.00	16.45	336	8.5	1.42	6.00	65.80	420			
LA34BJK-31	6	12.00	1.04	11.50	64.20	336	17.0	0.74	23.00	256.80	420			
LA34BJK-32	6	24.00	0.55	44.00	237.00	336	34.0	0.39	88.00	948.00	420			
LA34BJK-M200	4						6.0	2.00	3.0	33.2	420			
LA34BJK-M300	4						4.0	3.00	1.33	14.8	420			
LA34BJK-M400	4						3.0	4.00	0.75	8.3	420			
LA34BJK-M600	4						2.0	6.00	0.33	3.7	420			
LA34CKK-2	6	2.20	7.10	0.31	1.81	496	3.1	5.00	0.62	7.24	620	0.0265	121	
LA34CKK-1	6	2.80	5.38	0.52	3.10	496	4.0	3.85	1.04	12.40	620			
LA34CKK-3	6	4.30	3.58	1.20	7.65	496	6.1	2.54	2.40	30.60	620			
LA34CKK-37	6	6.00	2.31	2.60	15.50	496	8.5	1.63	5.20	62.00	620			
LA34CKK-38	6	12.00	1.17	10.30	60.00	496	17.0	0.82	20.60	240.00	620			
LA34CKK-39	6	24.00	0.59	41.00	249.00	496	34.0	0.41	82.00	996.00	620			
LA34CKK-M200	4						7.7	2.00	3.8	54.5	620			
LA34CKK-M300	4						5.1	3.00	1.7	24.2	620			
LA34CKK-M400	4						3.8	4.00	0.96	13.6	620			
LA34CKK-M600	4						2.6	6.00	0.43	6.1	620			

Solutions in motion



# Rotary Hybrid Stepping Motor 1.8°

Conventional

SIZE  
**34**  
3.38"  
DIA

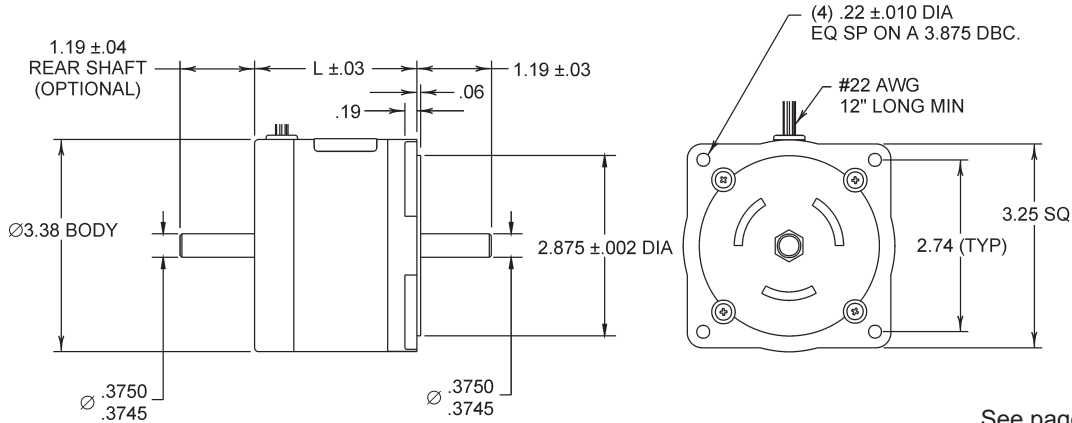

Size 34	
Model Series	Dimension "L" (inches)
LA34AGK	2.45
LA34BJK	3.70
LA34CKK	5.08

See page 38 for Connection Diagrams.  
For the rear shaft option, use the suffix "R" (for example, LA34AGK-1R).

## Pullout Torque Speed Curves

### Typical Unipolar Performance (6 Lead Motor): Constant Voltage Drive (L/R), 2 Phase On

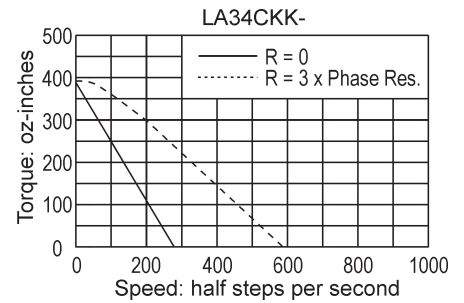
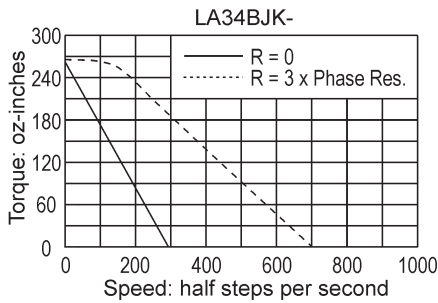
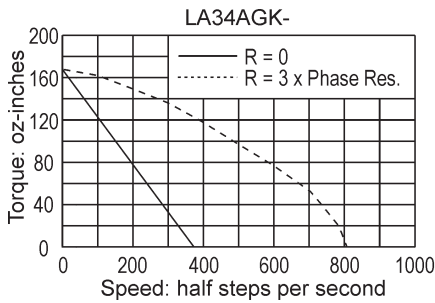

### Typical Bipolar Performance: 80 VDC Power Supply, 3 Amps/Phase

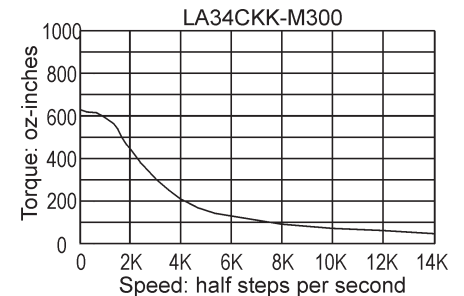
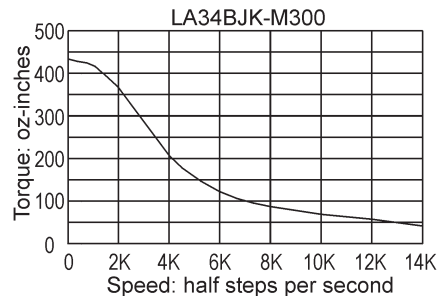
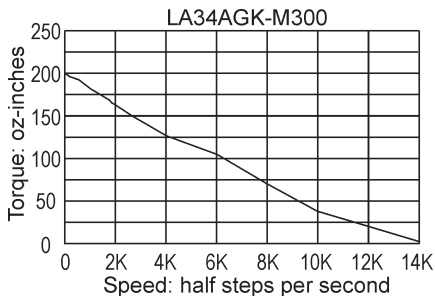

Solutions in motion





# Rotary Hybrid Stepping Motor 1.8°

SIZE  
**34**  
3.38"  
DIA

## High Torque

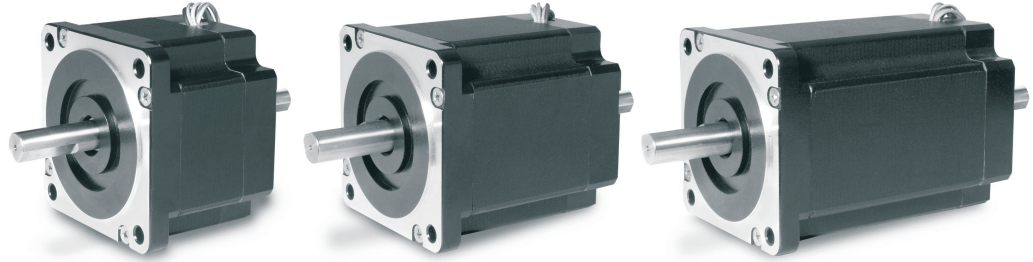

EADmotors Size 34 hybrid DC stepping motors are precision bi-directional devices with position accuracy of  $\pm 3\%$  non-cumulative.

Motors are totally enclosed with permanently lubricated ball bearings.

Standard motors have 4 or 6 leads. Motors with 5 or 8 leads can be furnished to meet existing applications.

EADmotors specializes in meeting the individual requirements of each application and offers engineering assistance for your design requirements.

## Electrical Ratings

Model Number	Number of Leads	Unipolar Connection					Bipolar Connection				
		Phase Voltage (VDC)	Phase Current (amps)	Phase Resistance (ohms)	Phase Inductance (mH)	Holding Torque (oz-in)	Phase Voltage (VDC)	Phase Current (amps)	Phase Resistance (ohms)	Phase Inductance (mH)	Holding Torque (oz-in)
LH3427-2	6	5.04	2.00	2.52	10.90	305	7.11	1.41	5.04	43.70	396
LH3427-3	6	3.00	3.00	1.00	4.34	305	4.24	2.12	2.00	17.40	396
LH3427-4	6	2.25	4.50	0.50	2.17	305	3.00	3.00	1.00	8.67	396
LH3427-M200	4						5.04	2.00	2.52	21.90	396
LH3427-M300	4						3.00	3.00	1.00	8.67	396
LH3427-M500	4						2.00	5.00	0.40	3.44	396
LH3439-2	6	7.86	2.00	3.93	17.10	610	11.08	1.41	7.86	68.50	793
LH3439-3	6	4.68	3.00	1.56	6.80	610	6.61	2.12	3.12	27.20	793
LH3439-4	6	3.51	4.50	0.78	3.40	610	4.68	3.00	1.56	13.60	793
LH3439-M200	4						7.86	2.00	3.93	34.30	793
LH3439-M300	4						4.68	3.00	1.56	13.60	793
LH3439-M500	4						3.10	5.00	0.62	5.39	793
LH3450-2	6	8.66	2.00	4.33	22.2	916	12.22	1.41	8.67	88.70	1190
LH3450-3	6	5.18	3.00	1.72	8.6	916	7.29	2.12	3.44	35.20	1190
LH3450-4	6	3.87	4.50	0.86	4.4	916	5.16	3.00	1.72	17.60	1190
LH3450-M200	4						8.66	2.00	4.33	44.30	1190
LH3450-M300	4						5.16	3.00	1.72	17.60	1190
LH3450-M500	4						3.40	5.00	0.68	6.98	1190

Model Number	Rotor Inertia (oz-in-sec <sup>2</sup> )	Weight (ounces)
LH3427-*	.0198	61.7
LH3439-*	.0382	98.8
LH3450-*	.0566	138.6

Solutions in motion



# Rotary Hybrid Stepping Motor 1.8°

High Torque

SIZE  
**34**  
**3.38"**  
DIA

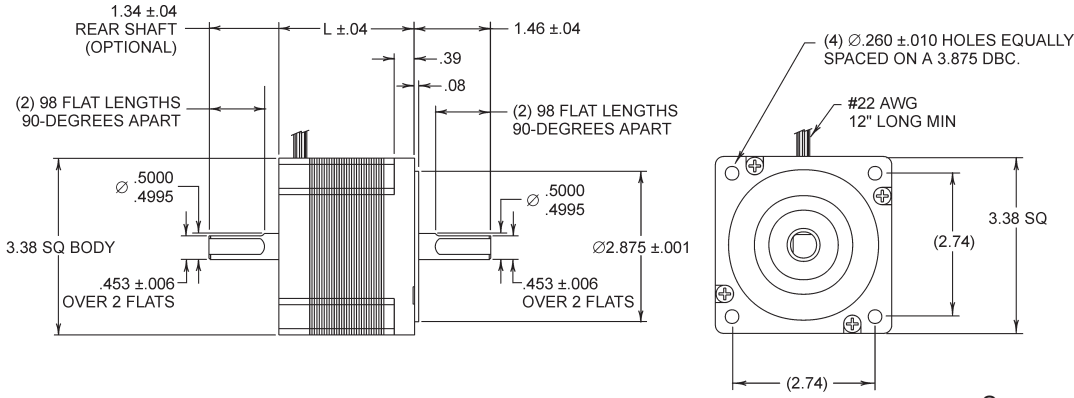

Size 34	
Model Series	Dimension "L" (inches)
LH3427	2.60
LH3439	3.78
LH3450	4.96

See page 38 for Connection Diagrams.

For the rear shaft option, use the suffix "R" (for example, LH3427-1R).

## Pullout Torque Speed Curves

### Typical Unipolar Performance (6 Lead Motor): Constant Voltage Drive (L/R), 2 Phase On

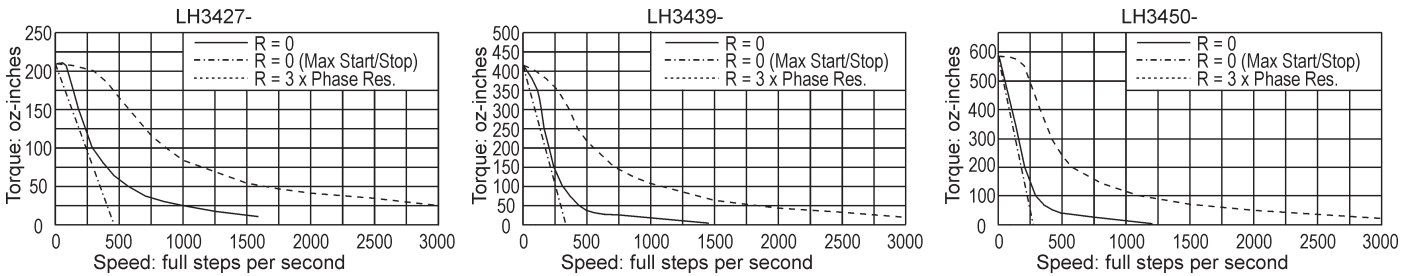

### Typical Bipolar Performance: 80 VDC Power Supply, 3 Amps/Phase

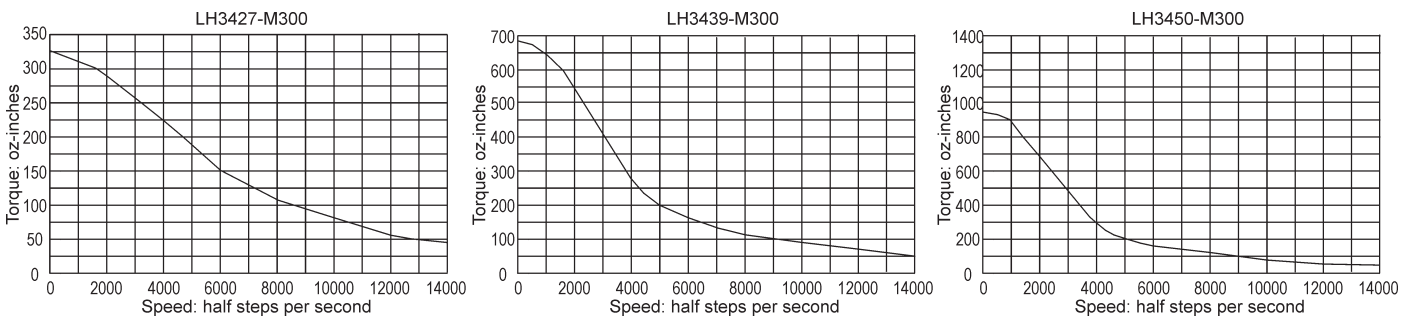

Solutions in motion



SIZE  
**42**  
4.28"  
DIA

# Rotary Hybrid Stepping Motor 1.8°

## Conventional

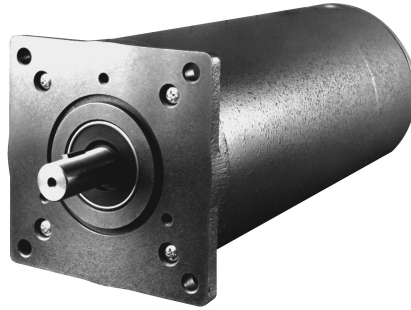

EADmotors Size 42 hybrid DC stepping motors are precision bi-directional devices with position accuracy of ±3% non-cumulative.

Motors are totally enclosed with permanently lubricated ball bearings.

EADmotors specializes in meeting the individual requirements of each application and offers engineering assistance for your design requirements.

### Electrical Ratings

Model Number	Unipolar Connection					Bipolar Connection								
	Phase Voltage (VDC)	Phase Current (amps)	Phase Resistance (ohms)	Phase Inductance (mH)	Holding Torque (oz-in)	Phase Voltage (VDC) series	Phase Voltage (VDC) parallel	Phase Current (amps) series	Phase Current (amps) parallel	Phase Resistance (ohms) series	Phase Resistance (ohms) parallel	Phase Inductance (mH) series	Phase Inductance (mH) parallel	Holding Torque (oz-in)
LA42BLK-5	2.26	6.11	0.37	3.5	650	3.2	1.6	4.32	8.64	0.74	0.185	14	3.5	810
LA42BLK-6	4.10	3.50	1.17	10.5	650	5.8	2.9	2.48	4.96	2.34	0.585	41.9	10.5	810
LA42BLK-7	7.93	1.77	4.47	40.1	650	11.2	5.6	1.25	2.50	8.94	2.24	160	40.1	810
LA42BLK-8	9.80	1.40	7.00	63.8	650	13.9	6.95	0.99	1.98	14	3.5	255	63.8	810
LA42BLK-200						7.0	3.5	2.0	4.0	3.5	0.4	63.8	16.0	810
LA42BLK-300						4.7	2.3	3.0	6.0	1.6	0.4	28.3	7.1	810
LA42BLK-500						2.8	1.4	5.0	10	0.6	0.150	10.2	2.6	810
LA42CNK-5	3.66	6.10	0.60	7.0	1150	5.18	2.54	4.31	8.62	1.2	0.3	28	7.0	1440
LA42CNK-6	4.60	4.74	0.97	11.3	1150	6.5	3.25	3.35	6.70	1.94	0.485	45	11.3	1440
LA42CNK-7	5.80	3.79	1.53	17.4	1150	8.2	4.1	2.68	5.36	3.06	0.765	70	17.4	1440
LA42CNK-8	7.44	3.10	2.40	26.9	1150	10.52	5.26	2.19	4.38	4.8	1.2	108	26.9	1440
LA42CNK-200						11.0	5.5	2.0	4.0	5.5	1.4	186	46.6	1440
LA42CNK-300						7.3	3.7	3.0	6.0	2.4	0.6	82.8	20.7	1440
LA42CNK-500						4.4	2.2	5.0	10	0.9	0.2	29.8	7.5	1440
LA42HRK-5	2.40	10.40	0.23	2.6	1650	3.4	1.7	7.3	14.6	0.46	0.115	10.4	2.6	2100
LA42HRK-6	3.20	8.40	0.38	4.0	1650	4.5	2.25	6.0	12.0	0.76	0.19	16	4.0	2100
LA42HRK-7	3.85	6.80	0.57	6.9	1650	5.4	2.7	4.8	9.6	1.14	0.285	27.6	6.9	2100
LA42HRK-8	4.50	5.20	0.86	10.6	1650	6.3	3.15	3.7	7.4	1.72	0.43	42.4	10.6	2100
LA42HRK-200						12.5	6.3	2.0	4.0	6.25	1.6	140	35	2100
LA42HRK-300						8.3	4.2	3.0	6.0	3.04	0.76	64	16	2100
LA42HRK-500						5.0	2.5	5.0	10	1.0	0.25	22.2	5.6	2100

Model Number	Rotor Inertia (oz-in-sec <sup>2</sup> )	Weight (ounces)
LA42BLK-*	0.055	216
LA42CNK-*	0.114	320
LA42HRK-*	0.172	424

Solutions in motion



# Rotary Hybrid Stepping Motor 1.8°

Conventional

SIZE  
**42**  
4.28"  
DIA

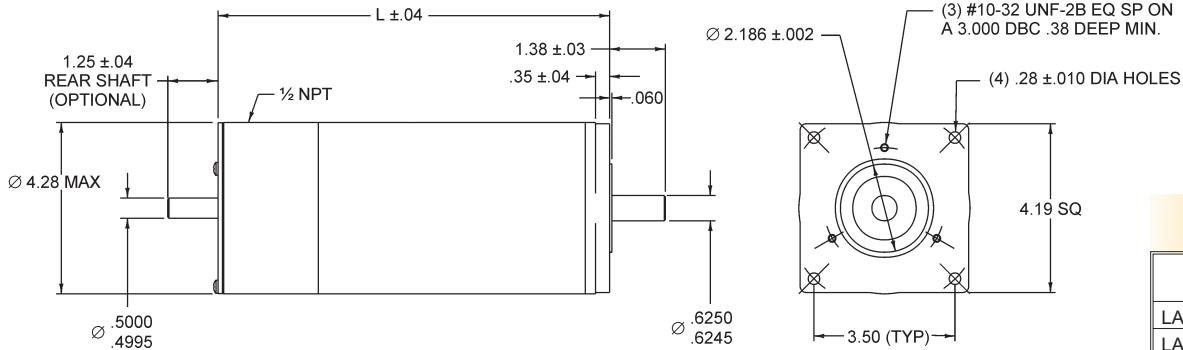

## Size 42

Model Series	Dimension "L" (inches)
LA42BLK	5.39
LA42CNK	7.56
LA42HRK	9.90

See page 38 for Connection Diagrams.  
For the rear shaft option, use the suffix "R" (for example, LA42BLK-300R).

## Pullout Torque Speed Curves

### Typical Bipolar Performance: 80 VDC Power Supply, 3 Amps/Phase—Series

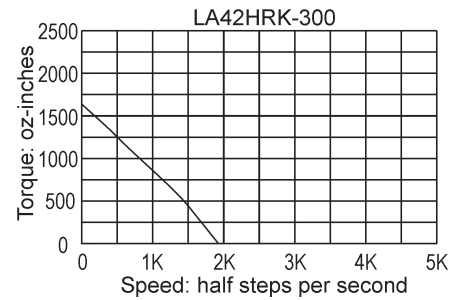
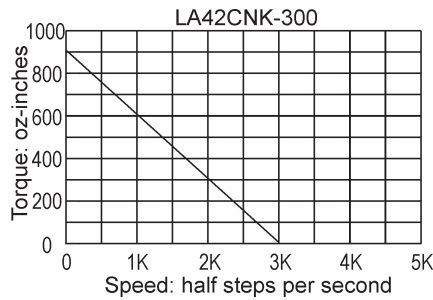
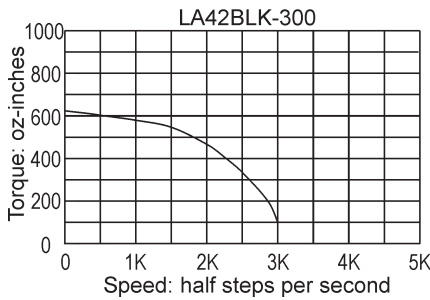

### Typical Bipolar Performance: 80 VDC Power Supply, 6 Amps/Phase—Parallel

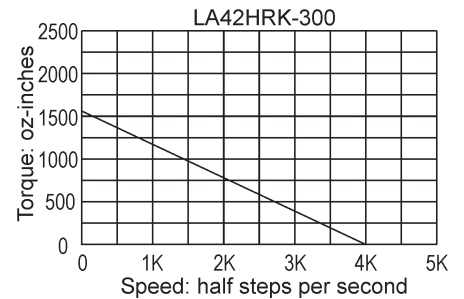
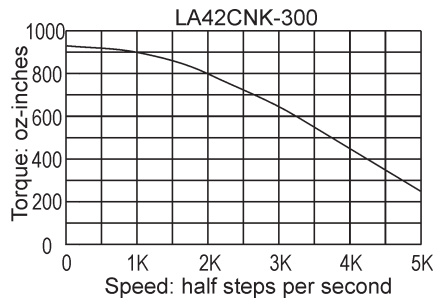
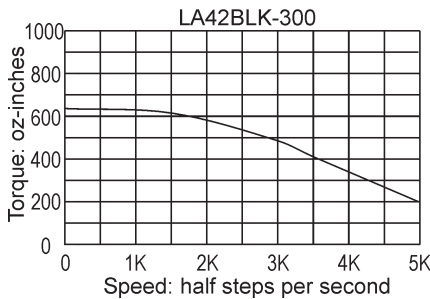

Solutions in motion





SIZE  
**17**  
**1.57"**  
SQ

# Linear Actuator

## Conventional

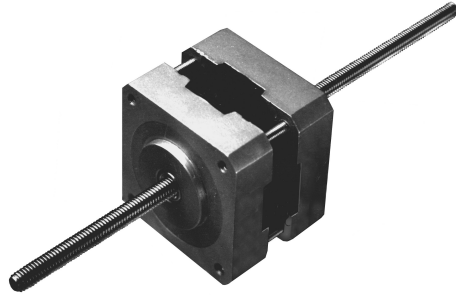

EADMotors Size 17 linear actuators are based on the 1.8° hybrid stepping motor. Size 17 linear actuators are bi-directional devices and are totally enclosed with permanently lubricated ball bearings.

The internal rotating nut is made of SAE 660 bearing bronze and the actuating leadscrew is made of cold rolled steel.

Leadscrew lubrication is required for maximum life. Lubricants containing molybdenum disulfide are recommended. The lubricant used in tests conducted to develop these force speed curves is available in two tube sizes:

¼ oz. Leadscrew Lube  
P/N 12210105

¾ oz. Leadscrew Lube  
P/N 12210106

Note: Anti-backlash nuts can be made available.

### Part Number Description

ZB17GBK \_ \_ \_

Thread Description  
(N, R, or P)

Leadscrew Length  
(1-inch increments)

Winding Number

### Electrical Ratings

Model Number	Number of Leads	Unipolar Connection				Bipolar Connection				Rotor Inertia (oz-in-sec <sup>2</sup> )	Weight (ounces)
		Phase Voltage (VDC)	Phase Current (amps)	Phase Resistance (ohms)	Phase Inductance (mH)	Phase Voltage (VDC)	Phase Current (amps)	Phase Resistance (ohms)	Phase Inductance (mH)		
ZB17GBK_-10-_	6	4.00	0.95	4.20	2.9	5.60	0.67	8.40	11.6	0.00024	7.0
ZB17GBK_-11-_	6	6.00	0.63	9.60	4.9	8.50	0.45	19.20	19.6		
ZB17GBK_-12-_	6	12.00	0.32	38.40	22	17.00	0.23	76.80	88.0		
ZB17GBK_-200-_	4					1.90	2.00	0.95	1.4		

### Leadscrew Specifications

Letter Designation	Thread Description	Thread Lead (inches)	Linear Travel per 1.8° Step (inches)	Maximum Linear Force (pounds)	
				Unipolar Connection	Bipolar Connection
N	#10-32UNF	0.03215	0.00015625	21	35
R	#10-32UN(2)*	0.0625	0.0003125	20	32
P	#10-32UN(4)*	0.1250	0.000625	16	27

\* Number of starts to the leadscrew: (2) = 2 starts, (4) = 4 starts, etc.

Solutions in motion



# Linear Actuator

Conventional

SIZE  
**17**  
**1.57"**  
SQ

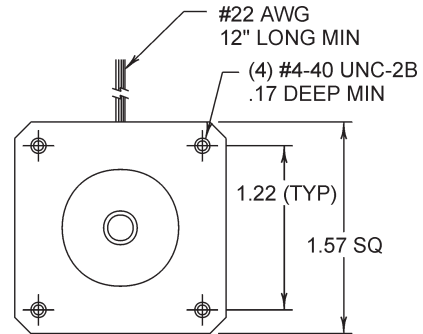
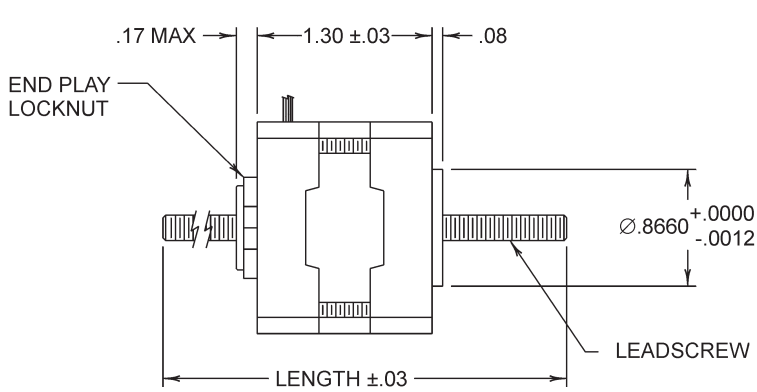

See page 38 for Connection Diagrams.

## Typical Unipolar Performance (6 Lead Motor): Constant Voltage Drive (L/R), 2 Phase On

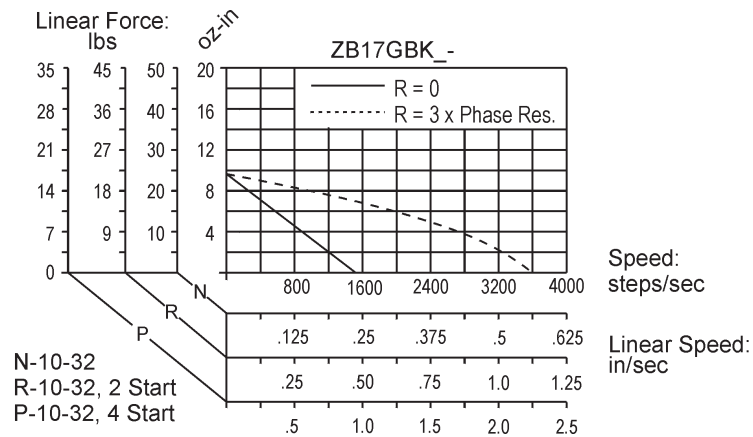

## Typical Bipolar Performance: 40 VDC Power Supply, 2 Amps/Phase

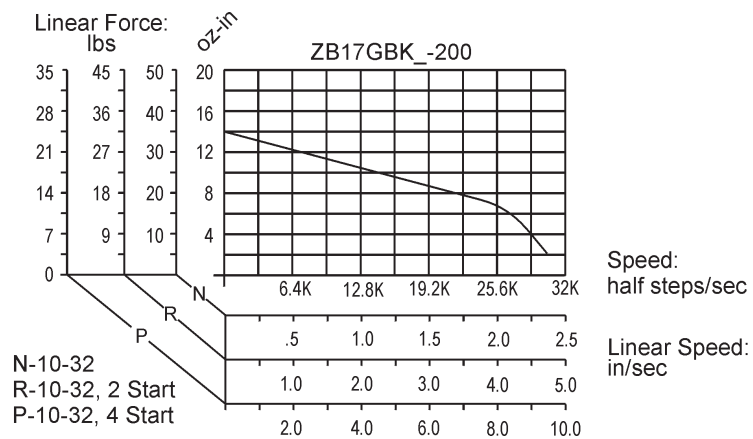

Solutions in motion



# DuraPlus Linear Actuator

SIZE

L1

1.65"  
SQ

## High Torque

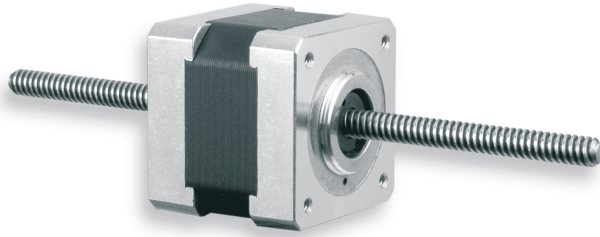

EADMotors high torque Size 17 stepping motors and our new *DuraPlus* system have been combined in our L1 series actuator. The L1 frame *DuraPlus* actuator is a precision engineered device based on a high performance 1.8° stepping motor with an integrated rotating nut. The nut is fabricated from a wide range of optional engineered polymers or SAE 660 bearing bronze to suit the application requirement. The standard polymer used for the catalog offering is Delrin AF. For details, visit [www.eadmotors.com](http://www.eadmotors.com).

The actuating screw is made of precision rolled stainless steel designed to minimize tolerances in positioning applications. When combined with the polymer nut, the *DuraPlus* system provides longer life and smoother, quieter operation than conventional designs.

Leadscrew lubrication is not required for polymer nuts; however, it is recommended for maximum life. Consult the factory for assistance with choice of lubricants.

Note: Anti-backlash nuts, custom leadscrews, and anti-rotation options are available.

## Part Number Description

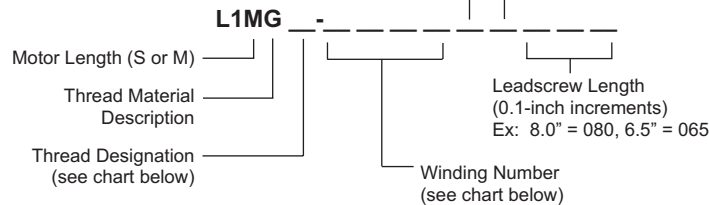

Encoder Option	
B	100 CPR
C	200 CPR
E	400 CPR
F	500 CPR
X	No Encoder

\* Consult factory for encoder details.

Standard Leadscrew End Features	
A	#8-32 UNC-2A
B	#10-32 UNF-2A
C	M4 x 0.7
D	M5 x 0.8
E	∅ .187/.186 (3/16)
F	∅ .196/.195 (5mm)
G	∅ .157/.156 (4mm)
X	None

## Electrical Ratings

Model Number	Number of Leads	Unipolar/Bipolar	Phase Voltage (VDC)	Phase Current (amps)	Phase Resistance (ohms)	Phase Inductance (mH)	Model Number	Number of Leads	Unipolar/Bipolar	Phase Voltage (VDC)	Phase Current (amps)	Phase Resistance (ohms)	Phase Inductance (mH)
L1SG_-H10	6	U	4.0	0.95	4.2	2.5	L1MG_-H10	6	U	4.0	1.2	3.3	3.2
L1SG_-H11	6	U	6.0	0.62	9.6	5.8	L1MG_-H11	6	U	6.0	0.8	7.5	7.0
L1SG_-H12	6	U	12.0	0.31	38.5	23	L1MG_-H12	6	U	12.0	0.4	30	28
L1SG_-H13	6	U	9.6	0.40	24	15	L1MG_-H13	6	U	24.0	0.2	120	112
L1SG_-M100	4	B	3.8	1.00	3.8	4.8	L1MG_-M100	4	B	4.7	1.0	4.7	9.1
L1SG_-M150	4	B	2.8	1.50	1.9	2.3	L1MG_-M150	4	B	3.6	1.5	2.4	4.7
L1SG_-M200	4	B	1.9	2.00	0.95	1.2	L1MG_-M200	4	B	2.4	2.0	1.2	2.3

6-wire/Unipolar available as 4-wire/Bipolar (e.g., "-H10" is then "-M10"). See page 6 (LH1713=L1S; LH1715=L1M).  
NOTE: 6 lead motors-Unipolar data shown.

## Leadscrew Specifications

Letter Designation	Thread Description*	Thread Lead (inches)	Linear Travel per 1.8° Step (inches)	Approximate Linear Holding Force (pounds)**			
				L1S Unipolar	L1S Biipolar	L1M Unipolar	L1M Bipolar
J	1/4-40UN(1)	0.025	0.000125	29	48	43	70
V	1/4-32ACME(1)	0.03125	0.00015625	27	45	41	67
E	1/4-20ACME(1)	0.050	0.000250	26	43	38	63
A	1/4-16ACME(1)	0.0625	0.0003125	26	43	38	63
B	1/4-16ACME(2)	0.125	0.000625	21	35	32	52
F	1/4-20ACME(4)	0.200	0.001000	17	29	25	42
C	1/4-16ACME(4)	0.250	0.001250	14	24	20	34

\* Number of starts to the leadscrew: (1) = 1 start, (2) = 2 starts, etc.  
\*\* Recommended maximum linear force = 50 lb. (bearing performance limitation).

Solutions in motion



# DuraPlus Linear Actuator

High Torque

SIZE  
**L1**  
**1.65"**  
SQ

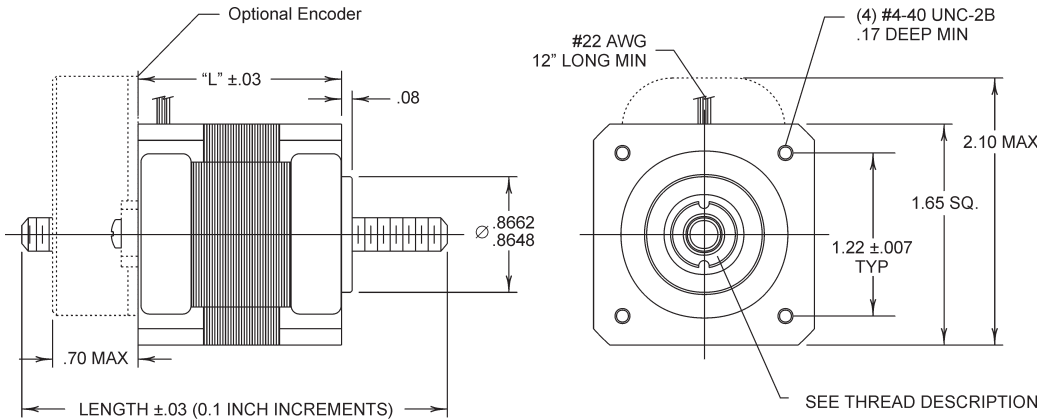

## Size L1

Model Series	L1S	L1M
Dimension "L" (inches)	1.28	1.52
Holding Torque (oz.in)	22	28
Rotor Inertia (oz-in-sec <sup>2</sup> )	0.00053	0.00081
Weight (oz)	7	9

See page 38 for Connection Diagrams.

### Typical Unipolar Performance (6 Lead Motor): Constant Voltage Drive (L/R), 2 Phase On

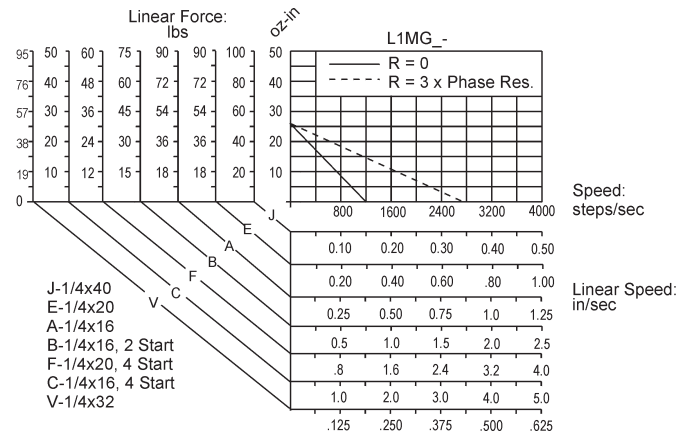
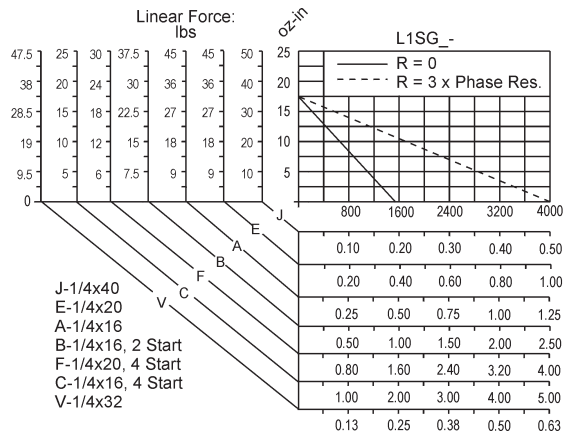

### Typical Bipolar Performance: 40 VDC Power Supply, 2 Amps/Phase

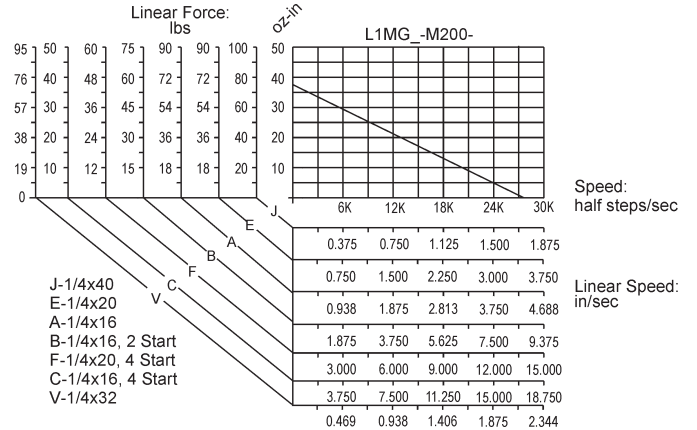
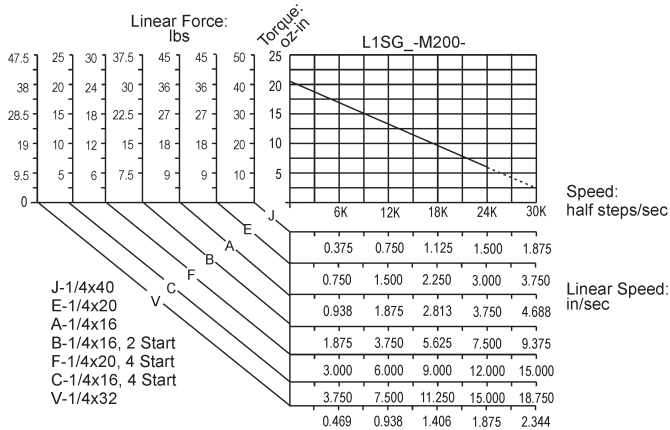

Solutions in motion



SIZE  
**23**  
2.25"  
DIA

# Linear Actuator

## Conventional

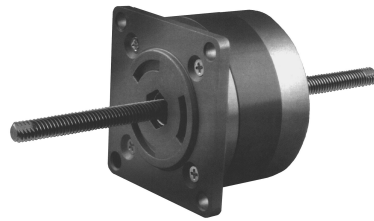

### Part Number Description

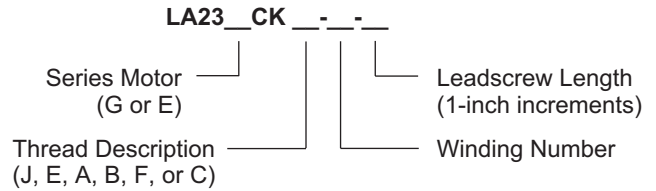

EADMotors Size 23 linear actuators are based on the 1.8° Size 23 hybrid stepping motor. As such, Size 23 linear actuators are bi-directional devices.

The internal rotating nut is made of SAE 660 bearing bronze and the actuating shaft is a rolled thread made of cold rolled steel.

Leadscrew lubrication is required for maximum life. Lubricants containing molybdenum disulfide are recommended. The lubricant used in tests conducted to develop these force speed curves is available in two tube sizes:

¼ oz. Leadscrew Lube  
P/N 12210105

¾ oz. Leadscrew Lube  
P/N 12210106

Note: Anti-backlash nuts can be made available.

## Electrical Ratings

Model Number	Number of Leads	Unipolar Connection				Bipolar Connection				Rotor Inertia (oz-in-sec <sup>2</sup> )	Weight (ounces)
		Phase Voltage (VDC)	Phase Current (amps)	Phase Resistance (ohms)	Phase Inductance (mH)	Phase Voltage (VDC)	Phase Current (amps)	Phase Resistance (ohms)	Phase Inductance (mH)		
LA23GCK_-209	6	1.30	5.90	0.22	0.3	1.84	4.18	0.44	1.0	0.00081	14
LA23GCK_-210	6	4.00	1.54	2.60	3.2	5.70	1.10	5.20	12.7		
LA23GCK_-211	6	6.00	1.20	5.00	5.4	8.50	0.85	10.00	21.6		
LA23GCK_-212	6	12.00	0.60	20.00	21.6	17.00	0.42	40.00	86.4		
LA23GCK_-213	6	24.00	0.30	80.00	81.2	34.00	0.21	160.00	324.6		
LA23GCK_-M100	4					6.0	1.00	5.90	16.9		
LA23GCK_-M200	4					3.0	2.00	1.50	4.2		
LA23GCK_-M300	4					2.0	3.00	0.66	1.9		
LA23GCK_-M400	4					1.5	4.00	0.37	1.1		
LA23ECK_-3	6	1.40	3.89	0.36	0.6	2.00	2.78	0.72	2.4	0.00166	19
LA23ECK_-6	6	3.40	1.55	2.20	4.1	4.80	1.09	4.40	16.2		
LA23ECK_-4	6	5.10	1.00	5.10	9.7	7.20	0.71	10.20	38.9		
LA23ECK_-11	6	6.00	0.97	6.20	10.6	8.50	0.68	12.40	42.4		
LA23ECK_-12	6	12.00	0.48	25.00	41.19	17.00	0.34	50.00	164.76		
LA23ECK_-13	6	24.00	0.25	96.00	131.40	34.00	0.18	192.00	525.60		
LA23ECK_-M100	4					5.6	1.00	5.6	25.6		
LA23ECK_-M200	4					2.8	2.00	1.4	6.4		
LA23ECK_-M300	4					1.9	3.00	0.62	2.8		
LA23ECK_-M400	4					1.4	4.00	0.35	1.6		

## Leadscrew Specifications

Letter Designation	Description	Thread Lead (inches)	Linear Travel per 1.8° Step (inches)	Maximum Linear Force (pounds)			
				GCK Unipolar	GCK Bipolar	ECK Unipolar	ECK Bipolar
J	1/4-40UN	0.0250	0.000125	60	76	100	140
E	1/4-20ACME	0.0500	0.000250	54	68	90	126
A	1/4-16ACME	0.0625	0.0003125	54	68	90	126
B	1/4-16ACME(2)*	0.1250	0.000625	45	57	75	105
F	1/4-20ACME(4)*	0.2000	0.001000	36	46	60	84
C	1/4-16ACME(4)*	0.2500	0.001250	30	38	50	70

\* Number of starts to the leadscrew: (2) = 2 starts, (4) = 4 starts, etc.

Solutions in motion





# Linear Actuator

Conventional

SIZE  
**23**  
2.25" DIA

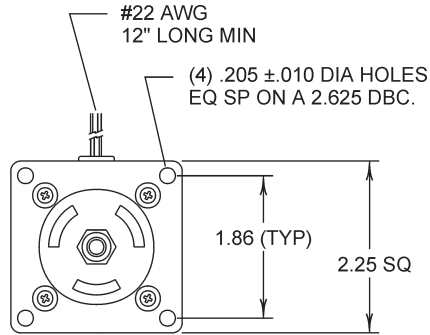
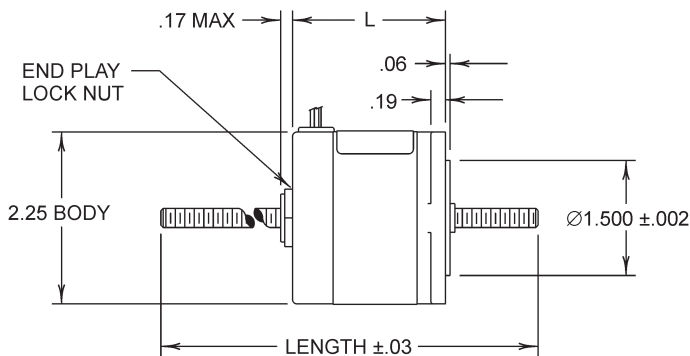

**Size 23**

Model Series	Dimension "L" (inches)
LA23GCK	1.6
LA23ECK	2.0

See page 38 for Connection Diagrams.

## Typical Unipolar Performance (6 Lead Motor): Constant Voltage Drive (L/R), 2 Phase On

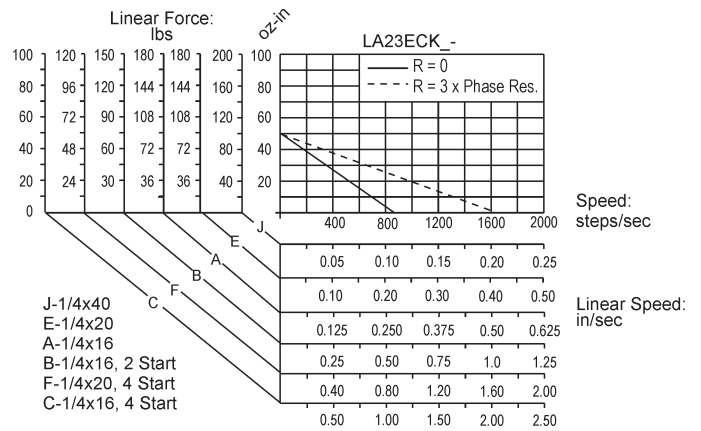
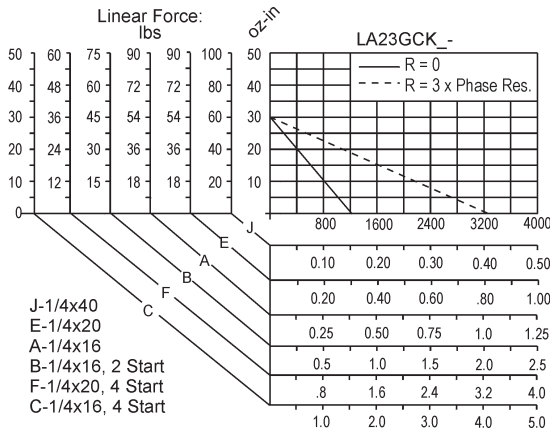

## Typical Bipolar Performance: 40 VDC Power Supply, 2 Amps/Phase

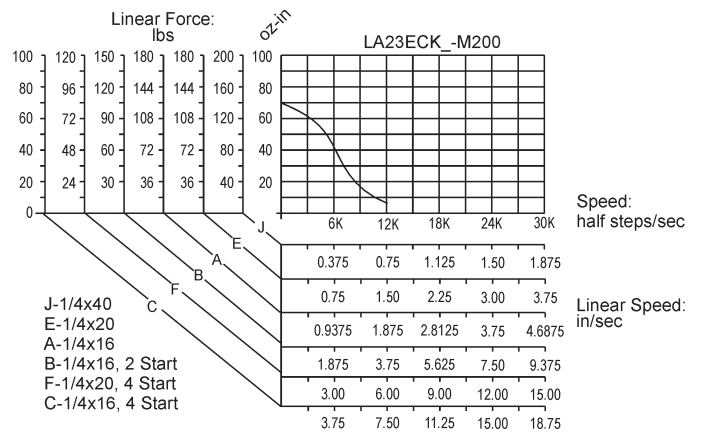
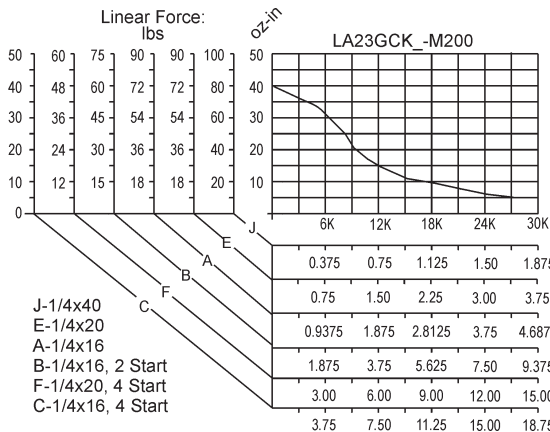

Solutions in motion



SIZE  
**L2**  
**2.22"**  
SQ

# DuraPlus Linear Actuator

## High Torque

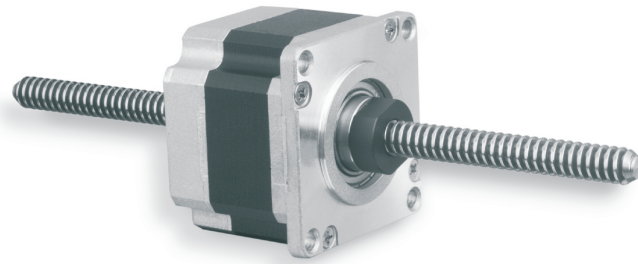

EADmotors high torque Size 23 stepping motors and our new *DuraPlus* system have been combined in our L2 series actuator. The L2 frame *DuraPlus* actuator is a precision engineered device based on a high performance 1.8° stepping motor with an integrated rotating nut. The nut is fabricated from a wide range of optional engineered polymers or SAE 660 bearing bronze to suit the application requirement. The standard polymer used for the catalog offering is Delrin AF. Visit [www.eadmotors.com](http://www.eadmotors.com) for details.

The actuating screw is made of precision rolled steel designed to minimize tolerances in positioning applications. When combined with the polymer nut, the *DuraPlus* system provides longer life and smoother, quieter operation than conventional designs.

Leadscrew lubrication is not required for polymer nuts; however, it is recommended for maximum life. Consult the factory for assistance with choice of lubricants.

Note: Anti-backlash nuts, custom leadscrews, and anti-rotation options are available.

### Part Number Description

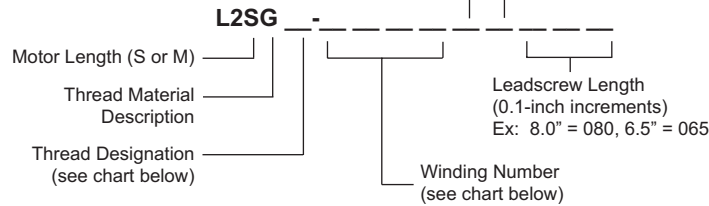

Encoder Option	
B	100 CPR
C	200 CPR
E	400 CPR
F	500 CPR
X	No Encoder
* Consult factory for encoder details.	

Standard Leadscrew End Features	
M	1/4-20 UNC-2A
N	1/4-28 UNF-2A
P	M6 x 1.0
R	∅ .235/.236 (6mm)
X	None

## Electrical Ratings

Model Number	Number of Leads	Unipolar Connection				Bipolar Connection				Rotor Inertia (oz-in-sec)	Weight (ounces)
		Phase Voltage (VDC)	Phase Current (amps)	Phase Resistance (ohms)	Phase Inductance (mH)	Phase Voltage (VDC)	Phase Current (amps)	Phase Resistance (ohms)	Phase Inductance (mH)		
L2SG_-H05	6	11.90	0.50	23.50	41.4	16.8	0.35	47.00	165.6	0.002	17
L2SG_-H1	6	6.00	1.00	6.00	10.8	8.49	0.71	12.00	43.2		
L2SG_-H2	6	3.00	2.00	1.57	2.6	4.24	1.41	3.14	10.4		
L2SG_-H3	6	1.80	3.00	0.61	1.0	2.55	2.12	1.22	4.0		
L2SG_-M100	4					5.80	1.00	5.78	20.3		
L2SG_-M200	4					3.00	2.00	1.50	5.2		
L2SG_-M300	4					1.80	3.00	0.60	2.0		

H05-H3 available with 4 leads (M05-M3).

## Leadscrew Specifications

Letter Designation	Thread Description*	Thread Lead (inches)	Linear Travel per 1.8° Step (inches)	Unipolar Maximum Force (pounds)	Bipolar Connection Maximum Linear Force (pounds)
Q	3/8-20ACME	0.0500	0.00025	100	125
T	3/8-16ACME	0.0625	0.0003125	98	115
S	3/8-10ACME	0.1000	0.000500	85	100

\* Anti-backlash nuts and custom leadscrew options are available.

Solutions in motion



# DuraPlus Linear Actuator

High Torque

SIZE  
**L2**  
**2.22"**  
SQ

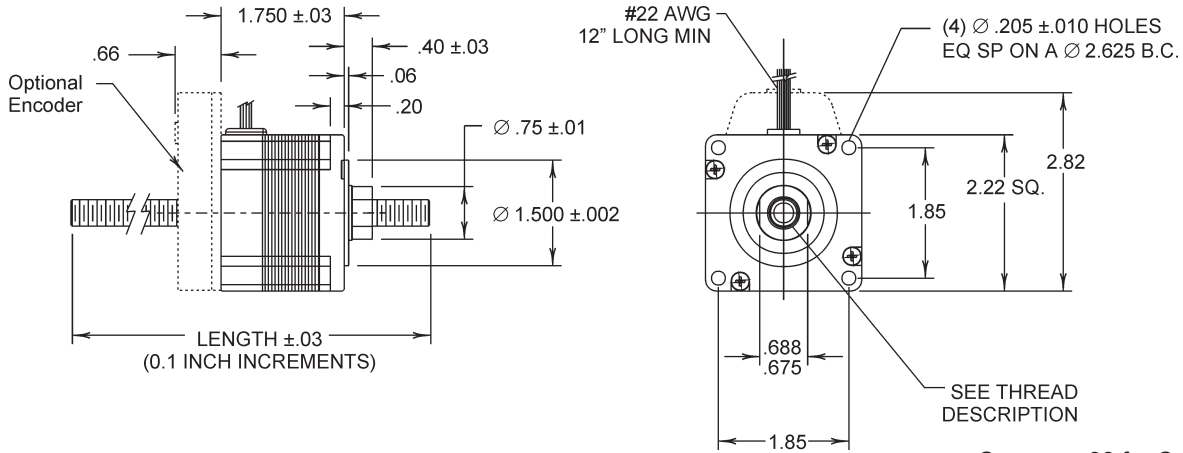

See page 38 for Connection Diagrams.

## Typical Unipolar Performance (6 Lead Motor): Constant Voltage Drive (L/R), 2 Phase On

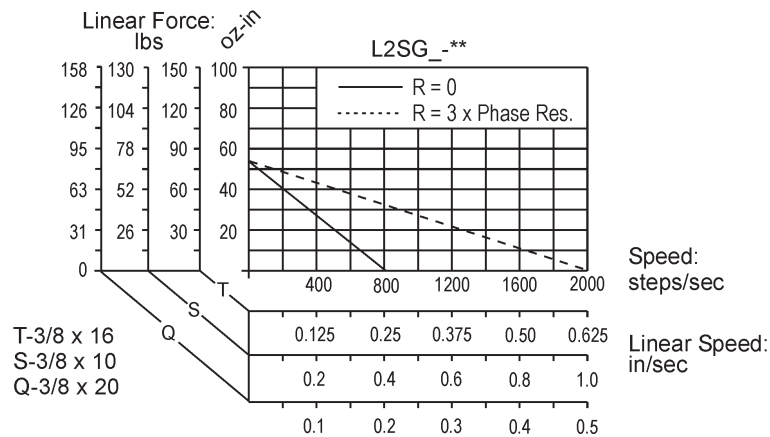

## Typical Bipolar Performance: 80 VDC Power Supply, 3 Amps/Phase

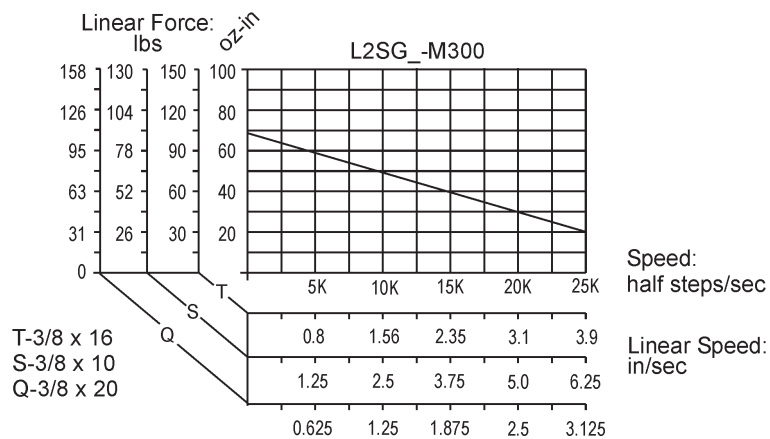

Solutions in motion



SIZE  
**34**  
**3.38"**  
DIA

# Linear Actuator

## Conventional

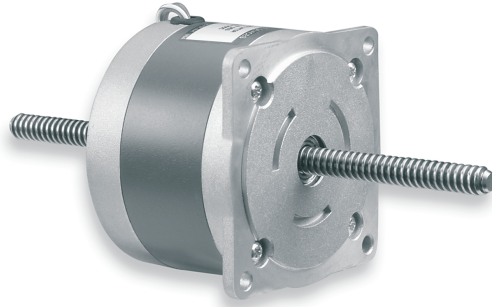

EADmotors Size 34 linear actuators are based on EAD's standard single stack 1.8° hybrid stepping motors. Size 34 linear actuators are totally enclosed with permanently lubricated ball bearings.

The internal rotating nut is made of bearing bronze and the actuating shaft is a rolled thread made of cold rolled steel.

Leadscrew lubrication is required for maximum life. Lubricants containing molybdenum disulfide are recommended. The lubricant used in tests conducted to develop these force speed curves is available in two tube sizes:

¼ oz. Leadscrew Lube  
P/N 12210105

¾ oz. Leadscrew Lube  
P/N 12210106

Note: Anti-backlash nuts and custom leadscrew options are available.

### Part Number Description

LA34AGK - - -

Thread Description  
(T or S)

Leadscrew Length  
(1-inch increments)

Winding Number

## Electrical Ratings

Model Number	Number of Leads	Unipolar Connection				Bipolar Connection				Rotor Inertia (oz.-in.-sec <sup>2</sup> )	Weight (ounces)
		Phase Voltage (VDC)	Phase Current (amps)	Phase Resistance (ohms)	Phase Inductance (mH)	Phase Voltage (VDC)	Phase Current (amps)	Phase Resistance (ohms)	Phase Inductance (mH)		
LA34AGK_-1	6	1.70	4.72	0.36	1.62	2.4	3.34	0.72	6.48	0.0091	48
LA34AGK_-2	6	2.60	3.06	0.85	4.15	3.7	2.17	1.70	16.60		
LA34AGK_-4	6	5.30	1.61	3.30	17.50	7.5	1.14	6.60	70.00		
LA34AGK_-9	6	12.00	0.67	18.00	80.00	17.0	0.47	36.00	320.00		
LA34AGK_-10	6	24.00	0.33	72.00	315.00	34.0	0.24	144.00	1260.00		
LA34AGK_-M200	4					4.4	2.00	2.2	20.4		
LA34AGK_-M300	4					2.9	3.00	0.96	9.07		
LA34AGK_-M400	4					2.2	4.00	0.55	5.1		
LA34AGK_-M600	4					1.5	6.00	0.24	2.27		

## Leadscrew Specifications

Letter Designation	Description	Thread Lead (inches)	Linear Travel per 1.8° Step (inches)	Bipolar Connection Maximum Linear Force (pounds)
T	3/8-16ACME	0.0625	.0003125	350
S	3/8-10ACME	0.1000	.000500	300

Solutions in motion

**EAD**<sup>TM</sup> **motors**  
Eastern Air Devices Inc.

# Linear Actuator

Conventional

SIZE  
**34**  
**3.38"**  
DIA

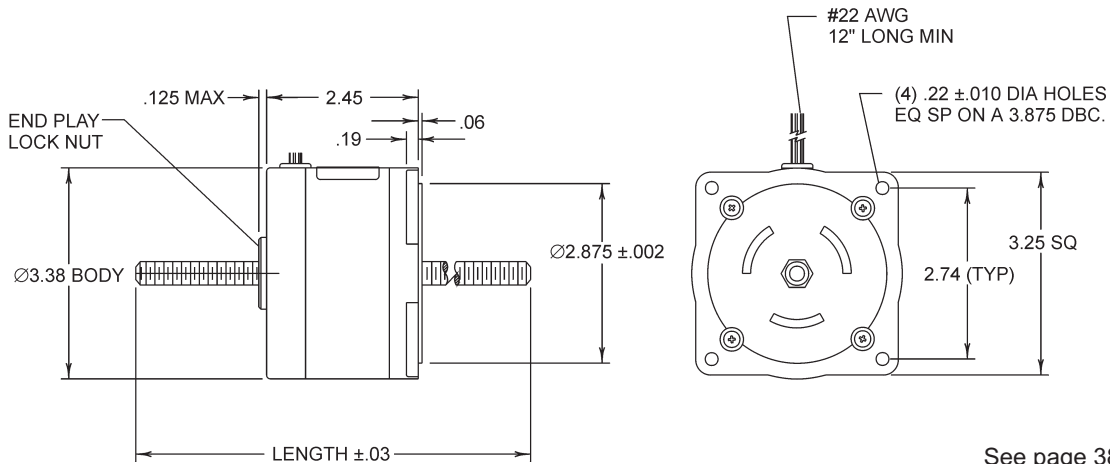

See page 38 for Connection Diagrams.

## Typical Unipolar Performance (6 Lead Motor): Constant Voltage Drive (L/R), 2 Phase On

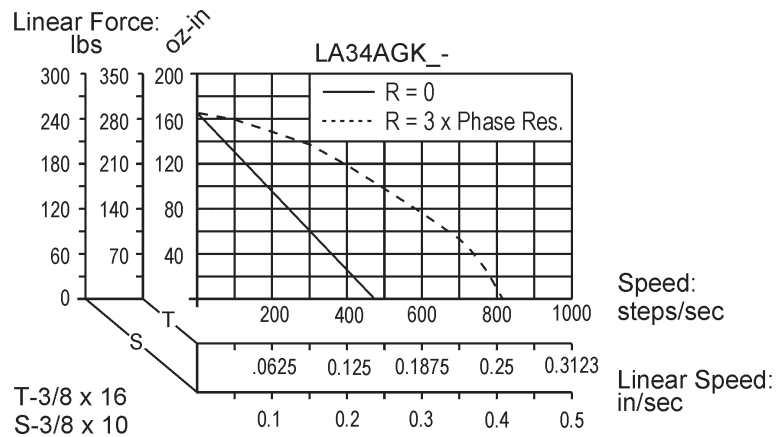

## Typical Bipolar Performance: 80 VDC Power Supply, 3 Amps/Phase

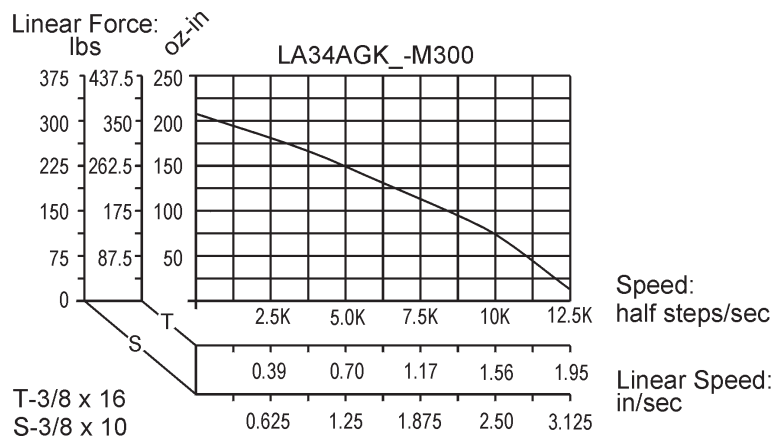

Solutions in motion





# DuraPlus Linear Actuator

SIZE  
**L3**  
**3.38"**  
SQ

## High Torque

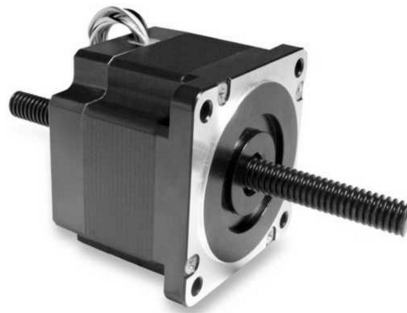

EADmotors high torque Size 34 stepping motors and the new *DuraPlus* system have been combined with shaft bearing enhancements in our L3 series actuator. The combination provides longer life with smoother and quieter operation than conventional designs.

The L3 actuator is a precision engineered device based on a high performance 1.8° stepping motor with an integrated rotating acme-threaded nut and a translating leadscrew. The nut is fabricated from Torlon for maximum thread life and, with high quality lubrication (vacuum compliant), couples with a leadscrew-hardening friction-reducing coating to provide long life, provide maximum efficiency, and minimize positioning deadband. The stainless steel leadscrew allows modifications to be made without introducing a corrosion tendency while maximizing positioning stiffness and performance uniformity over the full length of travel.

Options: Rotating leadscrew designs, anti-backlash nuts, anti-rotation features, Acetyl nuts, and alternate lubes are common enhancements.

Note: Design adjustments can carry penalties to load capacity and speed capacity. (Lubricant can be shipped separately.)

Encoder Option	
B	100 CPR
C	200 CPR
E	400 CPR
F	500 CPR
G	1000 CPR
H	2000 CPR
J	2048 CPR
T	1024 CPR
X	No Encoder

\* Consult factory for encoder details.

## Part Number Description

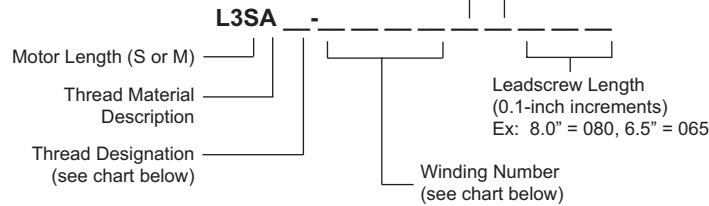

Standard Leadscrew End Features	
A	1/4-28UNF-2B
B	M6x1.0-6H
C	∅0.2502/∅.2499
D	∅0.2364/∅.2361
X	None

## Electrical Ratings

Model Number	Number of Leads	Phase Voltage (VDC)	Phase Current (amps)	Phase Resistance (ohms)	Phase Inductance (mH)	Holding Torque (oz-in)	Rotor Inertia (oz-in-sec <sup>2</sup> )	Weight (ounces)
L3SX-M200	4	5	2	2.5	21.9	396	0.04	65
L3SX-M300	4	3	3	1	8.67			
L3SX-M500	4	2	5	0.4	3.44			

## Leadscrew Specifications

Letter Designation	Thread Description*	Thread Lead (in)	Travel per Step (in)	Minor Diameter	Back Drivable	Maximum Thrust (lbs)
Q	3/8-20ACME(1)	0.05	0.000250	.2994	no	1060
T	3/8-16ACME(1)	0.0625	0.000312	.2857	no	970
W	3/8-12ACME(1)	0.0633	0.000416	.2632	no	860
S	3/8-10ACME(1)	0.1	0.000500	.2353	yes	780
A	1/2-10ACME(1)	0.1	0.000500	.3574	no	670
L	3/8-12ACME(2)	0.1667	0.000834	.2632	yes	580
F	1/2-10ACME(2)	0.2	0.001000	.3576	yes	470

\* Number of starts to the leadscrew: (1) = 1 start, (2) = 2 starts, etc.

Solutions in motion



# DuraPlus Linear Actuator

High Torque

SIZE  
**L3**  
**3.38"**  
SQ

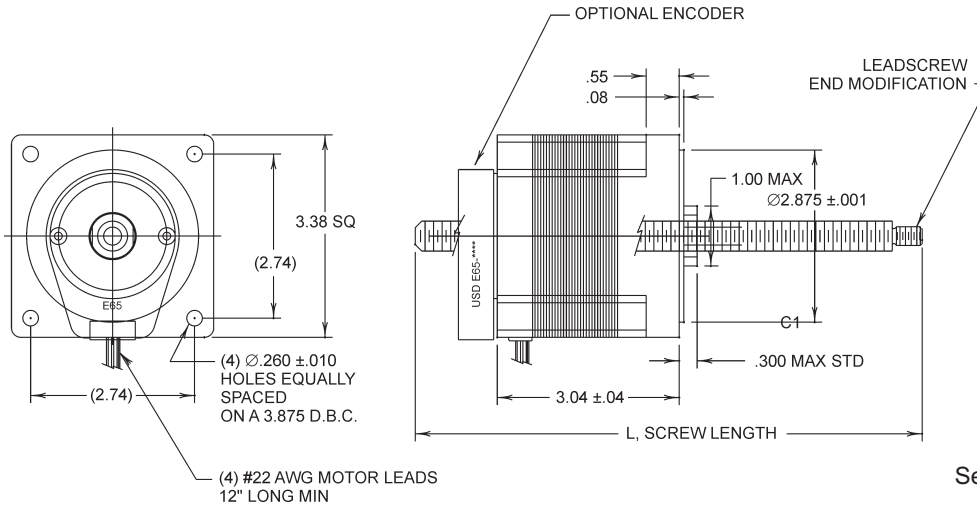

See page 38 for Connection Diagrams.

## Typical Bipolar Performance (4 Lead Motor): 80 VDC Power Supply, 3 Amps/Phase - High Speed Thread Series

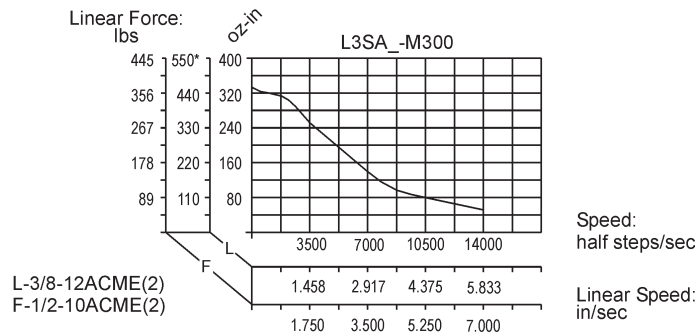

\* Alignment, lubricant and lube quantity, cleanliness, leadscrew balance, and machine vibration can, individually or as a group, prevent high speed operation.

## Typical Bipolar Performance: 80 VDC Power Supply, 3 Amps/Phase - High Force Thread Series

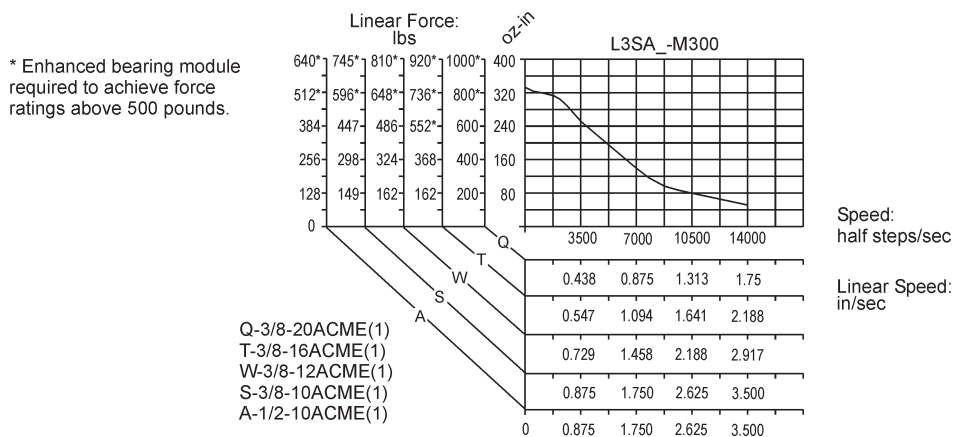

Solutions in motion



# 72 RPM AC Synchronous Motors

SIZE  
**23 34 42**  
 2.25" 3.38" 4.28"  
 DIA

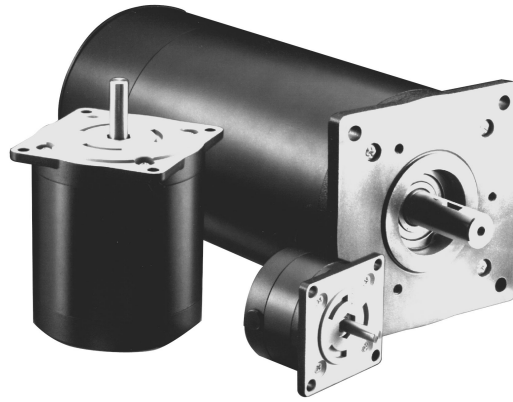

EADmotors 72 RPM synchronous motors are available in frame sizes 23, 34, and 42. These motors are totally enclosed with permanently lubricated ball bearings. And, the 72 RPM speed is obtained without gearing.

The motors may be reversed with a single pole double throw switch and may be stalled without any harmful effects.

In addition, versions of these motors can be provided to run at 60 RPM from 50 Hz AC.

## Electrical Ratings

Size	Model Number	Voltage (VAC)	Current (amps)	Torque (oz-in)	Rotor Inertia (oz-in-sec)	Resistor	Capacitor	Weight (ounces)
23	LA23ACB-1	120	0.10	25	.0012	500 OHM 5 WATT	0.75 mfd 330 VAC	20
	LA23ACB-2	120	0.08	44	.0017	100 OHM 5 WATT	0.75 mfd 330 VAC	20
	LA23BCB-1	120	0.20	100	.00331	400 OHM 25 WATT	2.25 mfd 330 VAC	32
34	LA34ADB-2	120	0.30	100	.0078	400 OHM 25 WATT	2.25 mfd 330 VAC	48
	LA34ADB-4	120	0.18	100	.0078	500 OHM 25 WATT	2.0 mfd 330 VAC	48
	LA34BGB-5	120	0.35	210	.0170	200 OHM 25 WATT	4.0 mfd 330 VAC	80
	LA34CJB-6	120	0.45	300	.0265	200 OHM 50 WATT	5.0 mfd 330 VAC	121
42	LB42BCB-1	120	0.4	175	.0550	250 OHM 25 WATT	3.75 mfd 330 VAC	150
	LB42BCB-2	120	0.6	275	.0550	150 OHM 50 WATT	6.5 mfd 330 VAC	150
	LB42CNB-1	120	0.6	450	.1140	150 OHM 50 WATT	6.5 mfd 330 VAC	254

## Connection Diagram

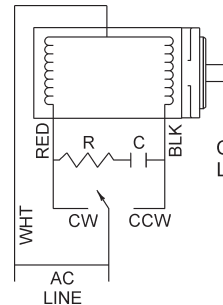

Connections for AC operation.  
 Lead end rotation.

Note:

Resistor/capacitor networks are supplied by the customer unless otherwise indicated.

Consult the factory for further information.

Solutions in motion



# 72 RPM AC Synchronous Motors

SIZE		
<b>23</b>	<b>34</b>	<b>42</b>
2.25"	3.38"	4.28"
DIA		

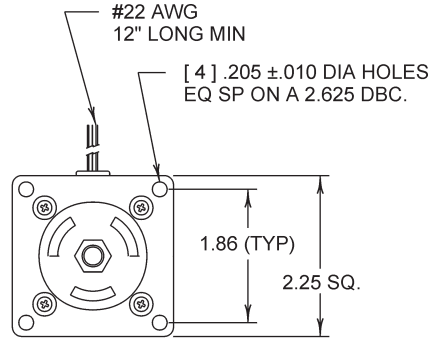
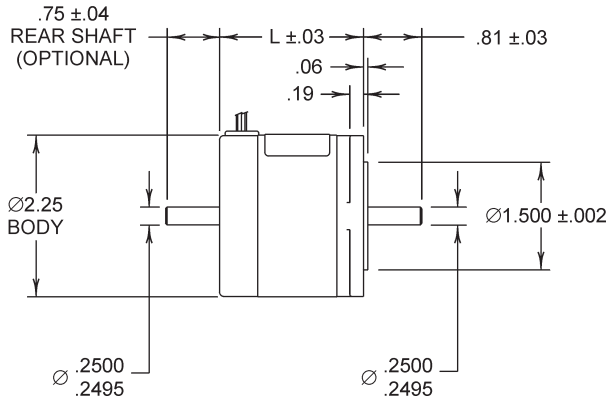

## Size 23

Model Series	Dimension "L" (inches)
LA23ACB-1	2.25
LA23ACB-2	2.25
LA23BCB-1	3.00

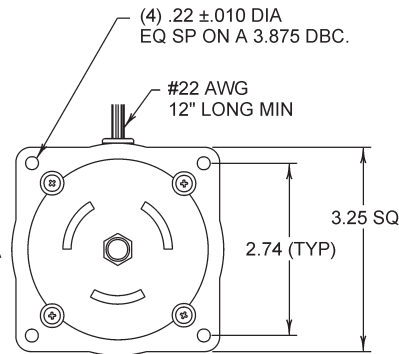
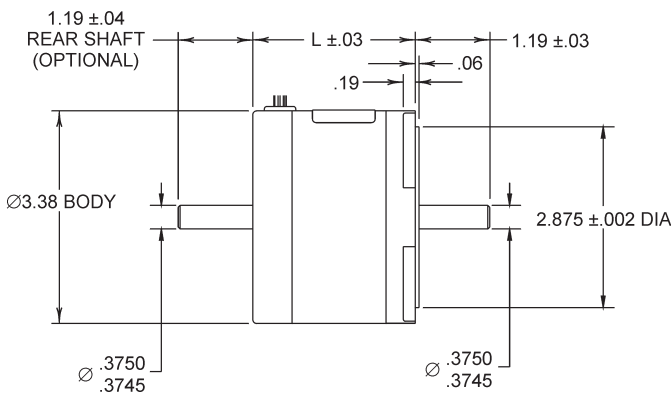

## Size 34

Model Series	Dimension "L" (inches)
LA34ADB-2	2.45
LA34ADB-4	2.45
LA34BGB-5	3.70
LA34CJB-6	5.06

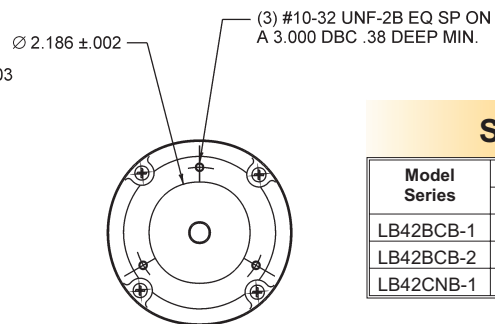
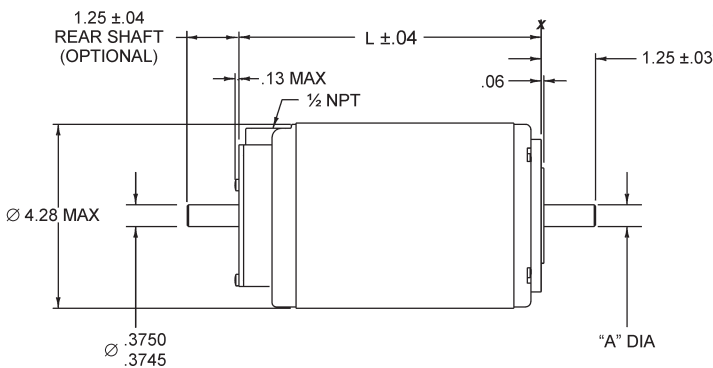

## Size 42

Model Series	Dimension (inches)	
	"L"	"A"
LB42BCB-1	4.80	.3750/.3745
LB42BCB-2	4.80	.3750/.3745
LB42CNB-1	6.97	.5000/.4995

Solutions in motion



# VR and PM Stepping Motors

## 7.5° 15° 45° 90°

SIZE  
**11 15 20**  
 1.06" 1.44" 2.00"  
 DIA

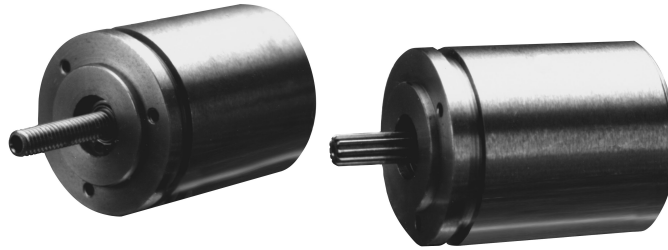

EADmotors Variable Reluctance (VR) and Permanent Magnet (PM) DC stepping motors are precision bi-directional devices used in paper tape punches, plotters, printers, and tape readers. Standard motors also are available with heat sinks.

The motors are totally enclosed with permanently lubricated ball bearings.

EADmotors specializes in meeting the individual requirements of each application and offers engineering assistance for your design requirements.

### Electrical Ratings

Size	Step Angle (Steps/rev)	Type	Model Number	Phase Voltage (VDC)	Phase Resistance (ohms)	Holding Torque (oz-in)	Rotor Inertia (oz-in-sec <sup>2</sup> )	Weight (ounces)
11	7.5	4ØVR	LD11EAY-1	28	95	2.3	.031 E-3	5.0
	15	4ØVR	LD11EAM-3	28	55	5.8	.014 E-3	4.7
	15	3ØVR	LD11EAL-1	28	80	2.7	.014 E-3	4.7
	45	4ØPM	LD11EAD-2	28	45	2.5	.017 E-3	4.5
	90	4ØPM	LD11EAE-4	28	60	2.5	.017 E-3	4.3
15	7.5	4ØVR	LD15EAY-4	28	55	8.0	.042 E-3	6.5
	15	4ØVR	LD15EAM-5	28	35	8.0	.010 E-3	6.5
	15	3ØVR	LD15EAL-4	28	16	5.8	.008 E-3	6.5
	45	4ØPM	LD15EAD-3	28	30	8.1	.071 E-3	10
	90	4ØPM	LD15EAE-1	28	20	11	.071 E-3	10
20	15	3ØVR	LD20ACL-10	28	10	45	.142 E-3	20
	15	3ØVR	LD20ACL-12	28	20	35	.142 E-3	20
	15	3ØVR	LD20DDL-10	12	2.1	65	.284 E-3	24
	15	4ØVR	LD20ACM-7	14	5	30	.142 E-3	20
	15	4ØVR	LD20ACM-8	28	10	42	.142 E-3	20
	15	4ØVR	LD20ACM-9	28	20	38	.142 E-3	20
	15	4ØVR	LD20ACM-10	28	30	30	.142 E-3	20
	15	4ØVR	LD20DDM-2	28	10	65	.284 E-3	24
	45	4ØPM	LD20ABD-2	28	12	15	.212 E-3	20
90	4ØPM	LD20ABE-1	28	12	20	.212 E-3	20	

Type	Shaft Description
b	PINION, 13T, 120DP, 20°, AGMA QUAL. No. 9
c	PINION, 10T, 96DP, 20°, AGMA QUAL. No. 9
d	PINION, 15T, 96DP, 20°, AGMA QUAL. No. 9

Solutions in motion





# VR and PM Stepping Motors 7.5° 15° 45° 90°

SIZE		
<b>11</b>	<b>15</b>	<b>20</b>
1.06"	1.44"	2.00"
DIA		

## Connection Diagrams

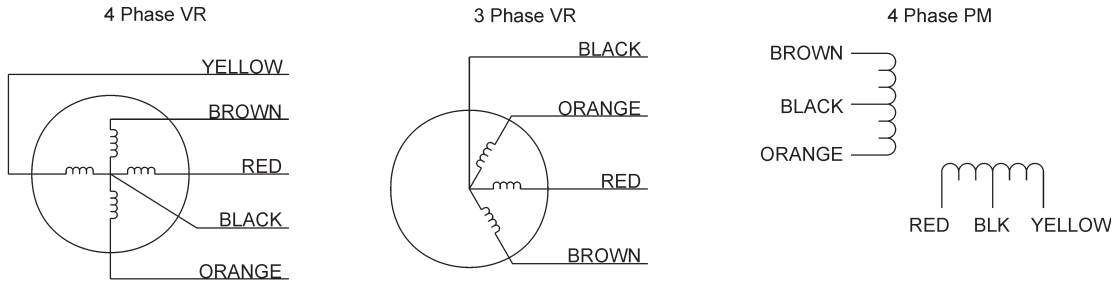

## Switching Sequence for Clockwise Rotation Facing Mounting End

One Phase Excitation

Step	BRN	RED	ORN	YEL	BLK
1	-	0	0	0	+
2	0	-	0	0	+
3	0	0	-	0	+
4	0	0	0	-	+

One Phase Excitation

Step	BRN	RED	ORN	BLK
1	-	0	0	+
2	0	-	0	+
3	0	0	-	+

One Phase Excitation

Step	BRN	RED	ORN	YEL	BLK
1	-	0	0	0	+
2	0	-	0	0	+
3	0	0	-	0	+
4	0	0	0	-	+

Two Phase Excitation

Step	BRN	RED	ORN	YEL	BLK
1	-	-	0	0	+
2	0	-	-	0	+
3	0	0	-	-	+
4	-	0	0	-	+

Two Phase Excitation

Step	BRN	RED	ORN	BLK
1	-	-	0	+
2	0	-	-	+
3	-	0	-	+

Two Phase Excitation

Step	BRN	RED	ORN	YEL	BLK
1	-	-	0	0	+
2	0	-	-	0	+
3	0	0	-	-	+
4	-	0	0	-	+

Solutions in motion



# VR and PM Stepping Motors 7.5° 15° 45° 90°

SIZE		
<b>11</b>	<b>15</b>	<b>20</b>
1.06"	1.44"	2.00"
DIA		

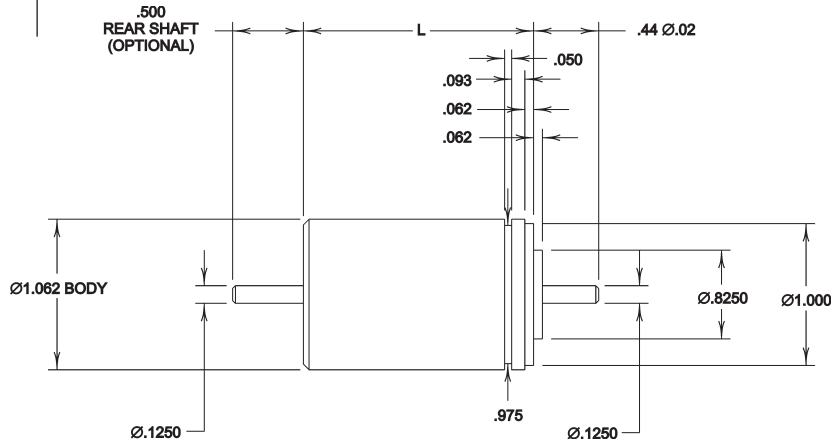

## Size 11

Model Series	Dimension "L" (inches)	Mounting Holes
LD11EAY-1	1.400	4-40 UNC-2B on .812 B.C., 90° apart
LD11EAM-3	1.625	
LD11EAL-1	1.625	
LD11EAD-2	1.625	
LD11EAE-4	1.625	

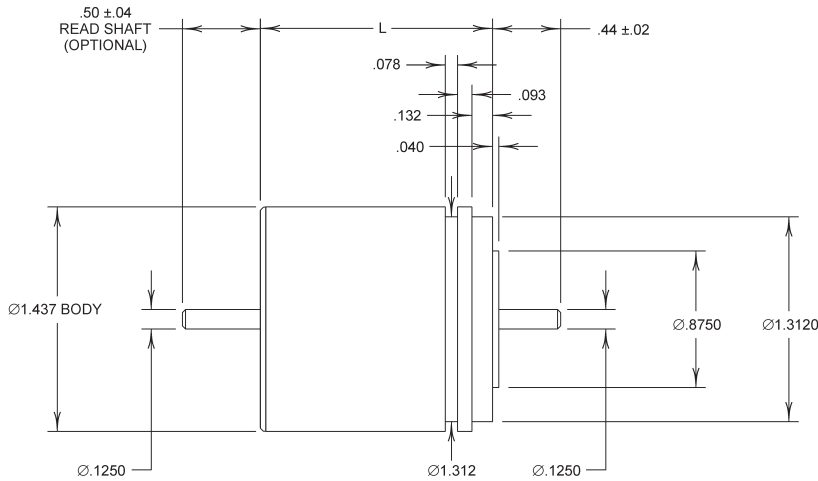

## Size 15

Model Series	Dimension "L" (inches)	Mounting Holes
LD15EAY-4	1.500	4-40 UNC-2B on 1.100 B.C., 90° apart
LD15EAM-5	1.500	
LD15EAL-4	1.500	
LD15EAD-3	2.100	
LD15EAE-1	2.100	

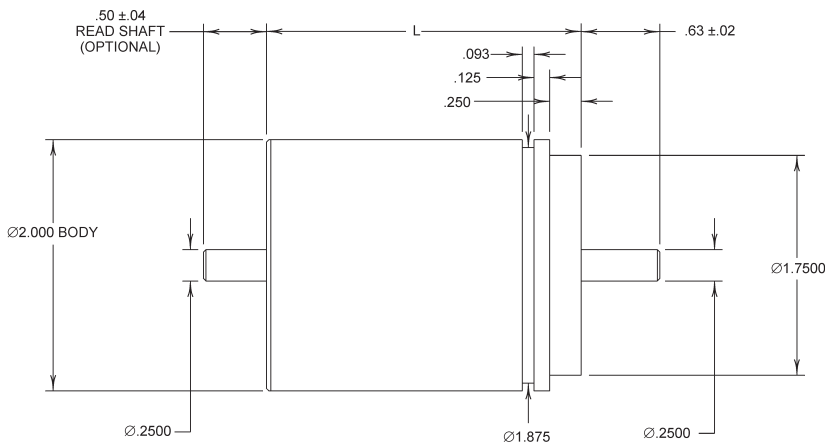

## Size 20

Model Series	Dimension "L" (inches)	Mounting Holes
LD20ACK-10	2.500	None
LD20ACL-12	2.500	
LD20DDL-10	3.500	
LD20ACM-7	2.500	
LD20ACM-8	2.500	
LD20ACM-9	2.500	
LD20ACM-10	2.500	
LD20DDM-2	3.500	
LD20ABD-2	2.500	
LD20ABE-1	2.500	

Solutions in motion



# VR and PM Stepping Motors 7.5° 15° 45° 90°

SIZE  
**11 15 20**  
 1.06" 1.44" 2.00"  
 DIA

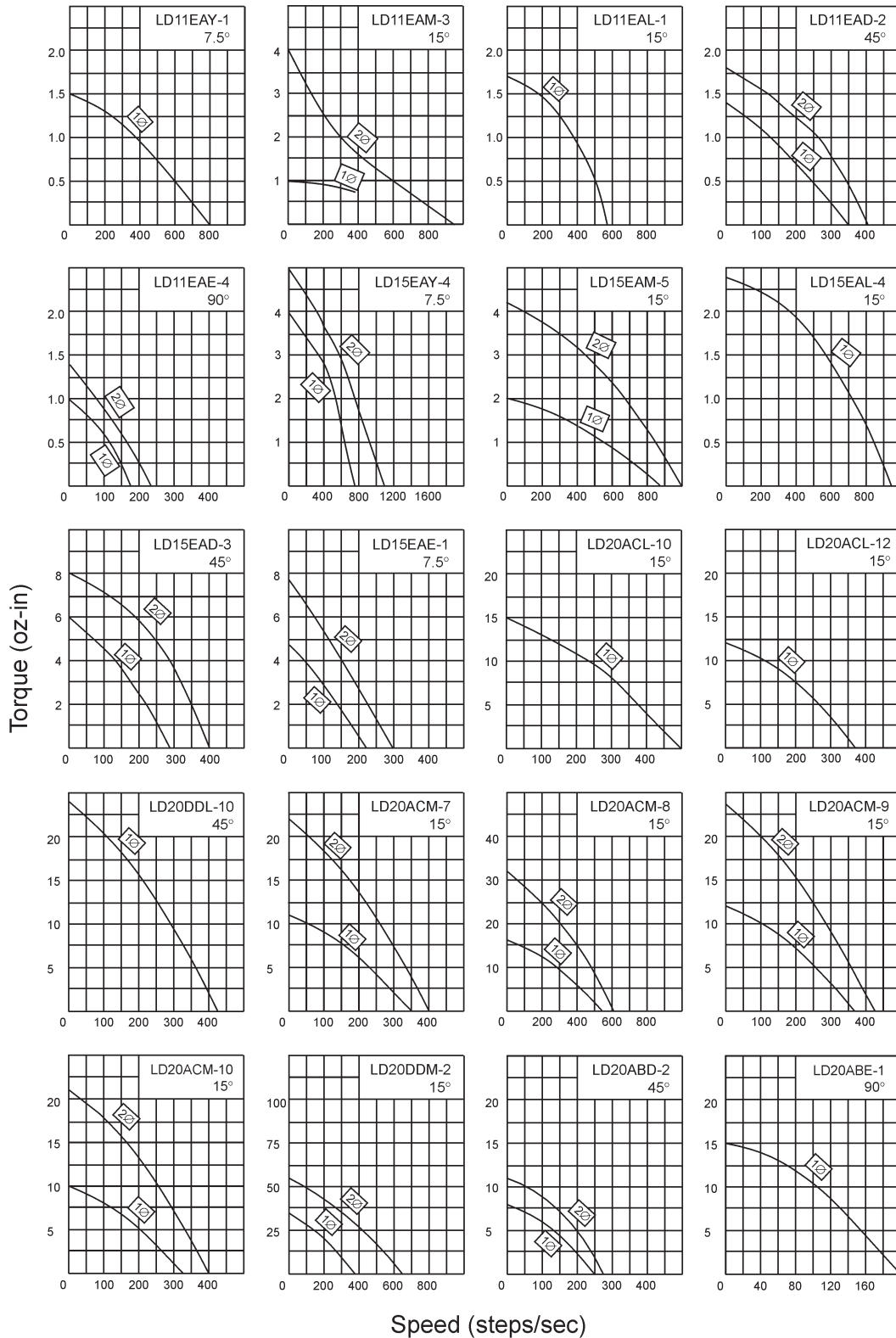

Solutions in motion



# Hybrid Motor Connection Diagrams

These diagrams show the unipolar and bipolar switching sequence. The direction of the rotation is viewed from the lead end.

**Notes:**

Other electrical and mechanical configurations are available upon request.

Class B insulation 130°C is standard. Higher rating is available upon request.

## Unipolar

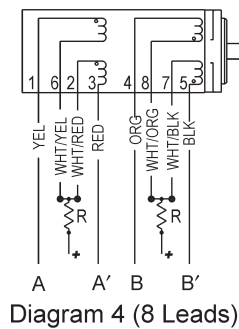
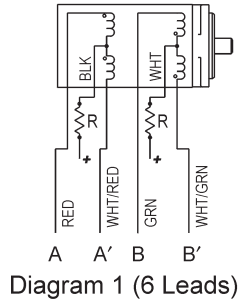

## Bipolar

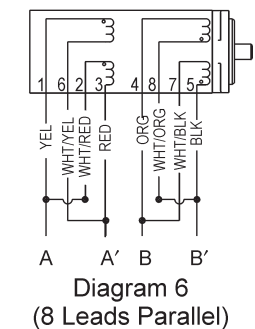
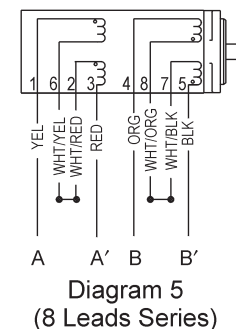
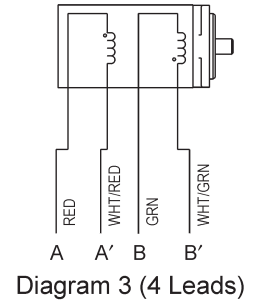
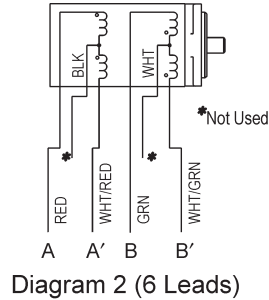

Step	A	A'	B	B'
1	—	—	—	—
2	—	—	—	—
3	—	—	—	—
4	—	—	—	—

2 Phase On

1	—	—	—	—
2	—	—	—	—
3	—	—	—	—
4	—	—	—	—
5	—	—	—	—
6	—	—	—	—
7	—	—	—	—
8	—	—	—	—

Half Step

1	—	—	—	—
2	—	—	—	—
3	—	—	—	—
4	—	—	—	—

1 Phase On

Step	A	A'	B	B'
1	+	—	+	—
2	+	—	—	+
3	—	+	—	+
4	—	+	+	—

2 Phase On

1	+	—	+	—
2	+	—	—	—
3	+	—	—	+
4	—	—	—	+
5	—	+	—	+
6	—	+	—	—
7	—	+	+	—
8	—	—	+	—

Half Step

1	+	—	—	—
2	—	—	—	+
3	—	+	—	—
4	—	—	+	—

1 Phase On

Solutions in motion



# Learn about our related products by visiting [www.eadmotors.com](http://www.eadmotors.com)

*Linear Actuators and Stepping Motors*

*Brushless DC Servo Motors*

*Induction Motors*

*Torque Motors*

*Rotors and Stators*

*Instrument Motors*

*Custom Design Specials*

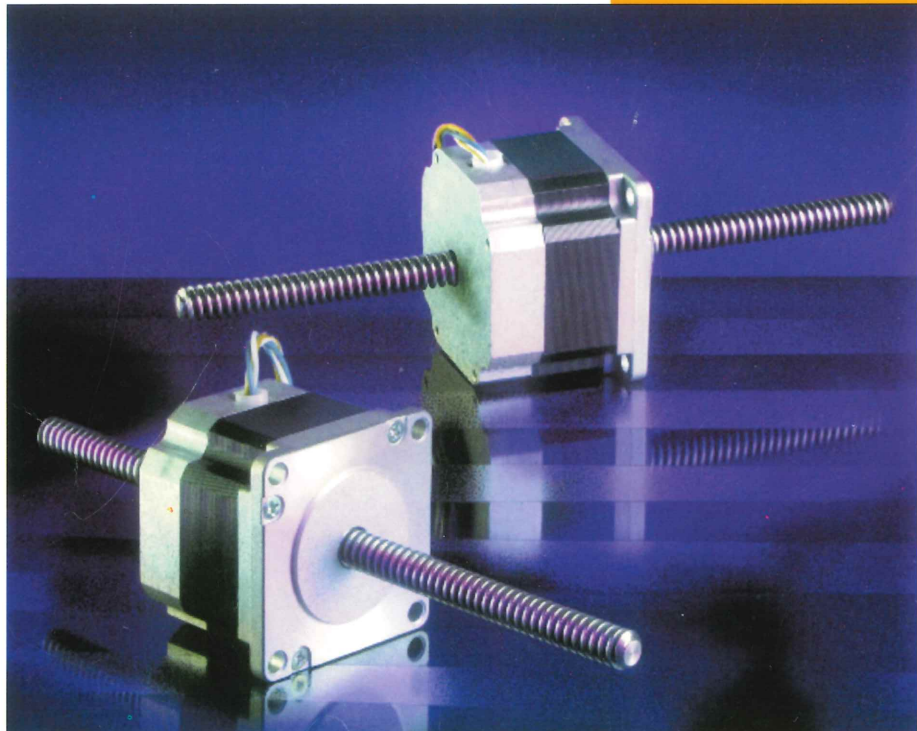

**EAD<sup>TM</sup> motors**  
Eastern Air Devices Inc.

Revision Date:  
November 2004

EAD motors  
Eastern Air Devices, Inc.  
1 Progress Drive, Dover, NH 03820  
Tel: (603) 742-3330  
Fax: (603) 742-9080  
e-mail: [info@eadmotors.com](mailto:info@eadmotors.com)  
[www.eadmotors.com](http://www.eadmotors.com)